



# HITACHI

## ZX210LC-6 HP | ZAXIS-6 series

Reliable solutions



### SPEC SUMMARY

Operating Weight      50,265 lb. (18,200 kg)  
Net Power (ISO 9249)    163.6 hp (122.0 kW) at 2,000 rpm

# ZAXIS210

Hydraulic Excavator



# ENGINEERED FOR ULTIMATE CONTROL

Whether you look at performance, efficiency, or cab comfort, Hitachi's latest range of excavators was designed around enhancing the operator experience and maximizing the fleet owner's bottom line.

We've looked closely at the day-to-day challenges you face as the owner of a successful business and have improved upon the comfort, efficiency and support we offer you over the life of your excavator.

By building the ZAXIS-6 series excavators around your needs, we have given you more control than ever of your fleet on whatever job site you are on.



# CONTENTS



6. Safety under control



8. Boost your uptime



10. Performance and fine control



13. More comfort features

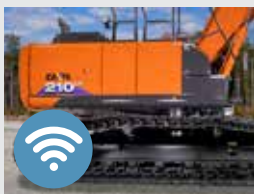

14. Durability comes standard



16. Reliability is the backbone of your business

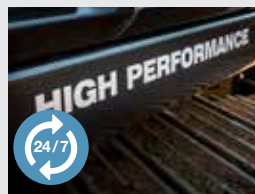

18. Get more from your excavator

# CONTROL YOU CAN COUNT ON

The new ZAXIS-6 medium-sized excavators with three working modes (ECO, Power, and High Power) puts you firmly in control, to have your machine perform how you need it to, when you need it to. Our excavators are backed by Hitachi technological expertise and our current 4-year, 4,000-hour STD warranty. We've got this, and you're in control.





A larger cab provides a more comfortable working environment.



The Aerial Angle® camera system and 7" LCD monitor takes visibility to a new level.



ConSite OIL sensors monitor oil quality proactively, easing your mind so that you can focus on the work that needs to be done.



The ConSite suite of apps track real-time performance metrics, making it easy for you to manage your machines' performance and productivity.



Improved access to components makes maintenance quick and easy.



The improved TRIAS II hydraulic system increases hydraulic efficiency while reducing fuel consumption at the same time.



The new powerful HP mode improves productivity and reduces cycle time.

# SAFELY UNDER CONTROL



Safety is vital to everyone on the job site and for the successful completion of any project. The Hitachi ZAXIS-6 excavators give you a superior view of your surroundings.

The Aerial Angle® camera system allows an exceptional 270-degree bird's-eye view of the surroundings. Three views of the machine's immediate environment can be selected, allowing the operator to choose the view that best suits the situation.

ZAXIS-6 excavators come standard with an impressive array of LED work lights, lighting up your job site at night like never before.



LED working lights improve visibility in challenging conditions.

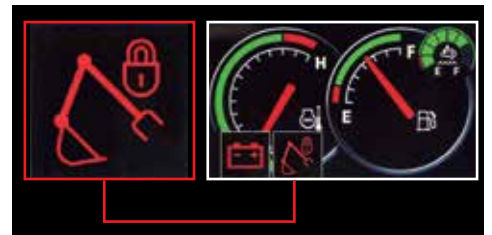

## Secure operation

Control-lever auto-lock helps prevent unintentional movement of the front, swing, travel, and attachment control functions. When the control-lever auto-lock is engaged, the icon will be illustrated on the monitor and an alarm will sound.

The ZX210LC-6 ROPS cab is pressurized to help protect operators from dust and debris.



Choose among different views to suit your jobsite and situation.

### **Aerial Angle® Camera comes standard**

The Aerial Angle® camera system offers exceptional visibility of the job site. With a push of the screen changeover button, an operator can choose to view a combination of all three cameras, providing a 270-degree view of the excavator; right and rearview camera view; or left, right, and rearview cameras separately depending on what view best fits the work environment and situation.

The excavator surrounding camera view is a composite of the images from the right, left, and rearview cameras, offering a 270-degree birds-eye view of the excavator's immediate environment.

 **erial angle®**

# BOOST YOUR UPTIME

## Ease of maintenance

The engine cover opens wide to reveal improved access to the engine compartment and components, making maintenance easier.

Ground level grouped filters make machine maintenance much easier

## Auto-Idle

Auto-Idle reduces engine speed when the machine is not working for 4 seconds.

## Auto-shutdown

Shuts down your excavator if left running between 1 to 30 minutes depending on the setting set within the cab monitor.

## Ground-level access and grouped maintenance points.



Ground-level access to urea tank



A larger electric fuel pump and enhanced injection system provide a precise quantity of pressurized fuel used to achieve more-efficient engine performance and reduce fuel consumption.



Wide opening engine cover for daily maintenance

Designed for durability and easy maintenance, ZAXIS-6 excavators increase uptime and reduce the total cost of ownership. >







# PERFORMANCE AND FINE CONTROL

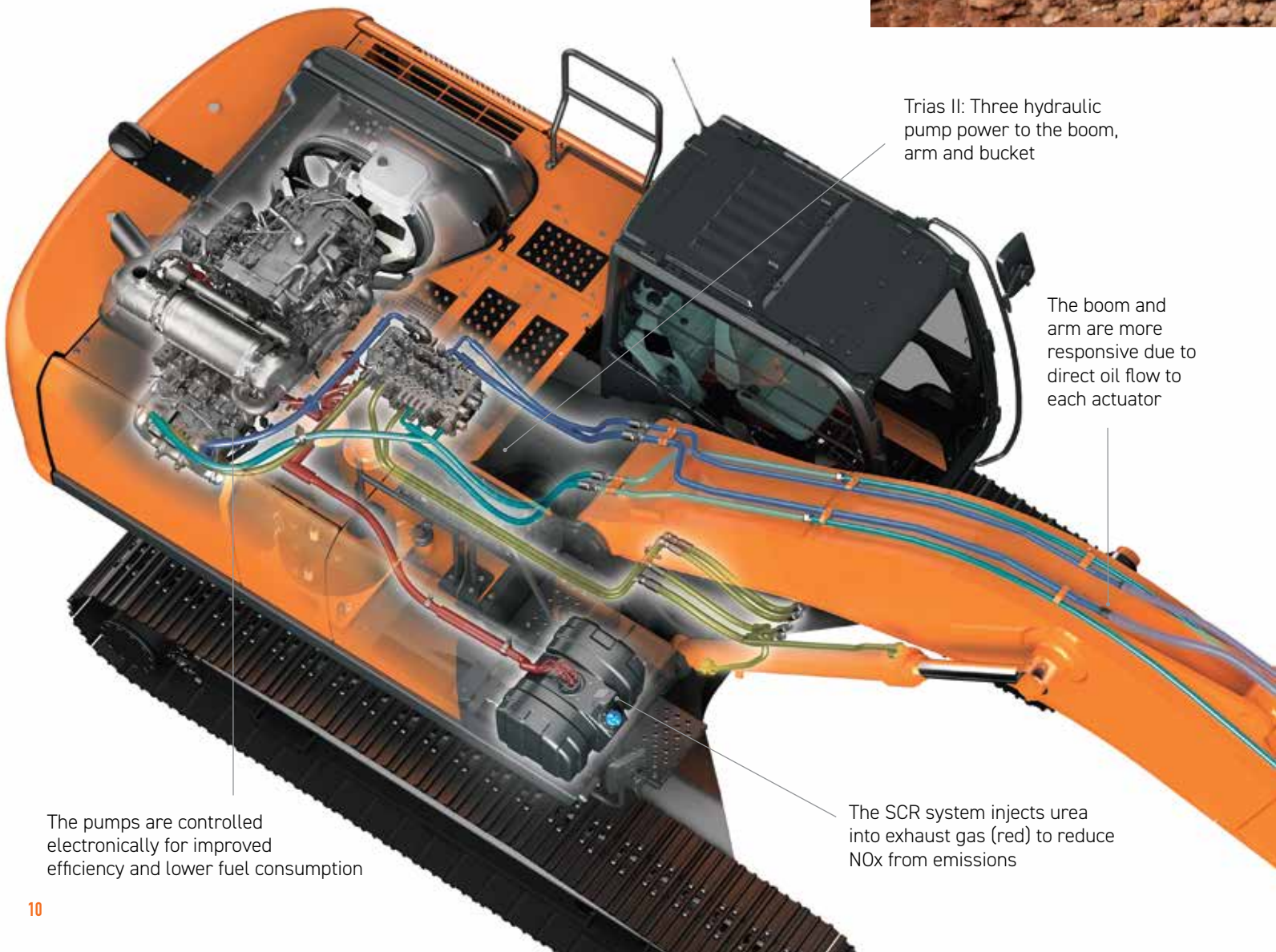

Trias II: Three hydraulic pump power to the boom, arm and bucket

The boom and arm are more responsive due to direct oil flow to each actuator

The pumps are controlled electronically for improved efficiency and lower fuel consumption

The SCR system injects urea into exhaust gas (red) to reduce NOx from emissions



### TRIAS II

The TRIAS II three-pump system ensures that the boom, arm, and bucket are responsive and extremely hydraulically efficient, which also results in better fuel efficiency.



Three solenoid valves ensure fine and sensitive front attachment control.

### Arm recirculation cancel system

The system increases arm roll-in speed in low-load conditions.

### Boom recirculating system

By recirculating the pressurized oil in the bottom of the boom cylinder when lowering the boom, the pressurized oil from the pump can be efficiently used by the arm, increasing arm speed.

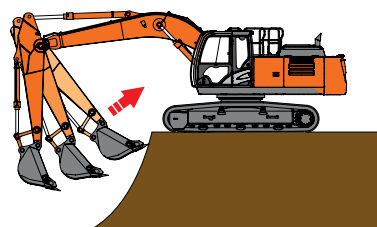

### Boost system

During arm roll-in and boom raise operations, excessive pressurized oil from the boom rod flows to the arm cylinder lower region, providing responsive arm operation.

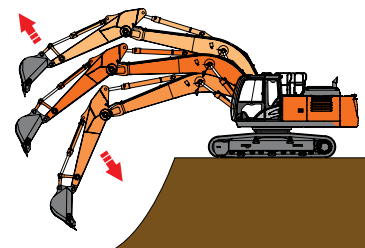

### H/P (High Power) mode



H/P mode increases engine speed and pump output torque when additional speed and power are needed during operation.

### Power boost

Power boost enhances digging force up to 10%, improving excavating and lifting performance.

### Machine performance

The ZX210LC-6 is equipped with two extra spools in the control valve, easing the installation attachments that require higher oil demand.



1

2

4

5

6

7

3

8

10

9

11

HITACHI

# MORE COMFORT FEATURES

**Enhanced comfort controls are at your fingertips in the refined cab of ZAXIS-6 excavators, giving you the power to perform with ease.**

#### **User-friendly monitor**

A large 7-inch LCD monitor allows the operator to check machine status at a glance in up to 32 languages.

#### **Improved visibility**

The optional front guard has been redesigned and improved, providing the operator with an even better view of the job site.

#### **A comfortable seat**

A fully adjustable seat, spacious cab, ergonomic controls, and advanced music system all contribute to the ultimate working environment. The addition of an adjustable sun visor reduces glare on those days when the sun is low in the sky.

#### **Advanced audio system**

The AM/FM radio is readily accessible from the monitor, and an auxiliary socket for devices such as MP3 players is linked to the sound system. This choice of entertainment helps to provide an enjoyable and productive working environment.

#### **Ease of use**

A USB port in the cab enables operators to charge smartphones and tablets while they work for added convenience.

#### **Cool, quiet cab**

Features have been added to the cab to make it quieter and to reduce dust ingress.



Comfortable cab space. ROPS certified CRESV cab.

- ① **Air conditioning and audio** are easily controlled via the monitor.
- ② **Low-reflective color 7" LCD monitor** is easy to view and navigate.
- ③ **USB power supply and smartphone holder** helps you stay connected.
- ④ **Drink holder** is easy to detach for cleaning.
- ⑤ **Additional joystick controls** for effortless operation.
- ⑥ **Ergonomic design** gives you convenient access to controls.
- ⑦ **Multifunctional control panel** makes operation easier.
- ⑧ **Improved sound isolation** makes this one of the quietest cabs on the market.
- ⑨ **User-friendly storage space** keeps your workspace tidy and clutter-free.
- ⑩ **Coat hooks** take care of your personal belongings.
- ⑪ **Optimal pedal layout** helps to reduce fatigue.

# DURABILITY COMES STANDARD



## **Enhanced fuel circuit**

A high-performance water separator and cold fuel resistance valve are integrated into the pre-filter for added protection against moisture. In addition, a large-capacity electric fuel pump supplies an appropriate amount of fuel to the engine for improved performance.

## **Save fuel**

Hydraulic loss is decreased by TRIAS II technology. It reduces the hydraulic oil returned to the tank due to the cooperative control of the pump and valve. This helps to lower fuel consumption by 8% in ECO mode with the same productivity.

## **Engine protection**

The combustion chamber is made from stronger materials, and the revised shape of the piston is designed to achieve cleaner emissions. These features will further enhance the reliability of the engine.



## Reinforced Undercarriage

### New shape of the lower roller

The lower roller has been redesigned to further help prevent mud ingress.

- Long-term durability
- Three track guards come standard for a more durable undercarriage.

### Integrated Idler and Adjuster

The front idler and adjuster cylinder have been integrated in the new ZAXIS-6, improving their durability.

Due to this integration, the bracket that had supported the adjuster cylinder is no longer required, resulting in less mud buildup.

## Reinforced idler bracket with slanted side frame

The side frame of the idler bracket is slanted on both sides, which enlarges the cross-sectional area of the external surface of the idler bracket.

The design of the idler bracket has been improved to make it easier to remove mud.



Reinforced undercarriage and increased crossbeam size and strength increase durability.

# RELIABILITY IS THE BACKBONE OF YOUR BUSINESS

## Easy maintenance

The engine cover can be conveniently opened fully from the platform. This provides easy access to the engine compartment and other components for routine maintenance.

- Dust screen prevents plugging, providing increased reliability.

## Greater flexibility

Thumb mode is included on the ZX210LC-6. This and 10 other modes can be registered on the monitor for easy fitting of attachments to increase versatility.



Quickly and easily select between multiple application modes.

## Long-lasting visibility

Eight standard LED lights enhance visibility for the operator, particularly at night. LED lights use less power, output more light, and last longer than halogen lights.



Filters within easy reach take just minutes to maintain.







# GET MORE FROM YOUR EXCAVATOR



The new high-performance features set the ZX210LC-6 HP apart.

## Lower emissions

The after-treatment device consists of a diesel oxidation catalyst (DOC), urea mixing pipe, SCR system, and silencer. This advanced technology helps to reduce emissions and noise levels.

## Engine aftertreatment device

Consisting of a DOC, a urea water mixing pipe, a SCR catalyst, and a silencer.

## Urea SCR system without DPF reduces NOx

Tier 4 Final is currently achieved by using a combination of urea SCR (Selective Catalytic Reduction) and DOC (Diesel Oxidation Catalyst). The DOC is basically maintenance-free. The amount of urea water is roughly 2% to 3% of the total fuel amount. Easy maintenance without a DPF.



Easy-access DEF tank

## Reliable Isuzu engine

Isuzu engines provide the reliability of 5+ years on-site experience in the North American market.



Checking DEF fluid level through Multi-function monitor.

## ConSite OIL

ConSite OIL monitors the oil condition to help ease your mind so that you can focus on the work at hand.

- The oil-monitoring sensor attached to the engine and hydraulic equipment monitors the oil status of each operating machine.

## Remote monitoring

Global e-Service allows for remote monitoring of your fleet, providing useful excavator data to enhance productivity and minimize downtime. Improve performance and maximize the efficiency of your excavator using the Global e-Service online management tool available 24/7 online.



# SPECIFICATIONS

## ENGINE

Model .....	Isuzu 4HK1
Type .....	4-cycle water-cooled, common rail direct injection
Aspiration .....	Variable geometry turbocharged, intercooled, cooled EGR
Aftertreatment .....	DOC and SCR system
No. of cylinders .....	4
Rated power	
ISO 14396: 2002 Gross	172 hp (128 kW) at 2,000 rpm
ISO 9249: 2007 Net.....	164 hp (122 kW) at 2,000 rpm
Maximum torque .....	494 lbf-ft (670 Nm) at 1,600 rpm
Piston displacement .....	317 cu. in. (5.19 L)
Bore and stroke .....	4.5 in. x 4.9 in. (115 mm x 125 mm)
Batteries .....	2 x 12 V/126 Ah

## HYDRAULIC SYSTEM

### Hydraulic Pumps

Main pumps .....	3 variable displacement axial piston pumps
Maximum oil flow .....	1 x 49.9 gal/m (1 x 189 L/min)
Pilot pump .....	2 x 56.0 gal/m (2 x 212 L/min)
Maximum oil flow .....	1 gear pump
Maximum oil flow	8.9 gal/m (33.6 L/min)

### Hydraulic Motors

Travel .....	2 variable displacement axial piston motors
Swing .....	1 axial piston motor

### Relief Valve Settings

Implement circuit .....	4,975 psi (34.3 MPa)
Swing circuit .....	4,699 psi (32.4 MPa)
Travel circuit .....	5,149 psi (35.5 MPa)
Pilot circuit .....	566 psi (3.9 MPa)
Power boost .....	5,511 psi (38.0 MPa)

### Hydraulic Cylinders

Unit: in (mm)

	Quantity	Bore	Rod diameter
Boom	2	4.7" (120)	3.3" (85)
Arm	1	5.3" (135)	3.7" (95)
Bucket	1	4.5" (115)	3.1" (80)

## UPPERSTRUCTURE

### Revolving Frame

D-section frame for resistance to deformation.

### Swing Device

Axial piston motor with planetary reduction gear is bathed in oil. Swing circle is single-row. Swing parking brake is spring-set/hydraulic-released disc type.

Swing speed .....	11.8 rpm
Swing torque .....	50,154 lbf-ft (68 kNm)

## UNDERCARRIAGE

### Tracks

Tractor-type undercarriage. Welded track frame using selected materials. Side frame welded to track frame. Lubricated track rollers, idlers, and sprockets with floating seals. Track shoes with triple grousers made of induction-hardened rolled alloy. Heat-treated connecting pins with dirt seals. Hydraulic (grease) track adjusters with shock-absorbing recoil springs.

### Numbers of Rollers and Shoes on Each Side

Upper rollers .....	2
Lower rollers .....	8
Track shoes .....	49
Track guards .....	3

### Travel Device

Each track driven by 2-speed axial piston motor. Parking brake is spring-set/hydraulic-released disc type. Automatic transmission system: High-Low.

Travel speeds .....	High: 0 to 3.4 mph (0 to 5.5 km/h)
	Low: 0 to 2.2 mph (0 to 3.5 km/h)

Maximum traction force .....	45,636 lbf (203 kN)
Gradeability .....	70% (35 degree) continuous

## ENVIRONMENT

Engine Emissions .....	EPA Final Tier 4/EU Stage IV
------------------------	------------------------------

## SOUND LEVEL

Sound level in cab according to ISO 6396: 2008 .....	*LpA 69 dB(A)
External sound level according to ISO 6395: 2008 and EU Directive 2000/14/EC .....	*LwA 101 dB(A)

\*At PWR mode

## SERVICE REFILL CAPACITIES

Unit: gal (L)

Fuel tank .....	106.5 (403)
Engine coolant .....	7.4 (28)
Engine oil .....	6.1 (23)
Swing device.....	1.6 (6.2)
Travel device (each side).....	1.8 (6.8)
Hydraulic system.....	63.4 (240)
Hydraulic oil tank.....	35.7 (135)
DEF/AdBlue® tank.....	15.1 (57)

## WEIGHTS AND GROUND PRESSURE

### Operating Weight and Ground Pressure

Shoe type	Shoe width Unit: in (mm)	Operating weight Unit: lb (kg)	Ground pressure Unit: psi (kPa)
Triple grouser shoes	32" (800)	50,265 (22,800)	5.08 (35)

Including 1.0 yd<sup>3</sup> (0.8 m<sup>3</sup>) (ISO 7451: 2007) heaped bucket weight 1,455 lb (660 kg) and counterweight 10,692 lb (4,850 kg).

## BASIC MACHINE WEIGHT AND COMPONENTS WEIGHT

### Basic Machine Weight and Overall Width

Excluding front end attachment, fuel, hydraulic oil and coolant, etc. Including counterweight.

Shoe type	Shoe width Unit: in (mm)	Weight Unit: lb (kg)	Overall width Unit: ft-in (mm)
Triple grouser shoes	32" (800)	40,124 (18,200)	10' 6" (3,190)

### Components Weight

Unit: lb (kg)

Counterweight	10,692 (4,850)
Boom (with arm cylinder and boom cylinder)	4,739 (2,150)
Arm (with bucket cylinder) 9 ft 7 in (2.91 m)	2,337 (1,060)
Bucket (ISO 7451: 2007) 1.0 yd <sup>3</sup> (0.8 m <sup>3</sup> )	1,455 (660)

## BUCKET AND ARM DIGGING FORCE

Unit: lbf (kN)

Arm length	9' 7" (2.91 m)
Arm crowd force* (ISO 6015: 2006)	25,628 (114)
Bucket digging force* (ISO 6015: 2006)	35,520 (158)

\* At power boost

# SPECIFICATIONS

## DIMENSIONS

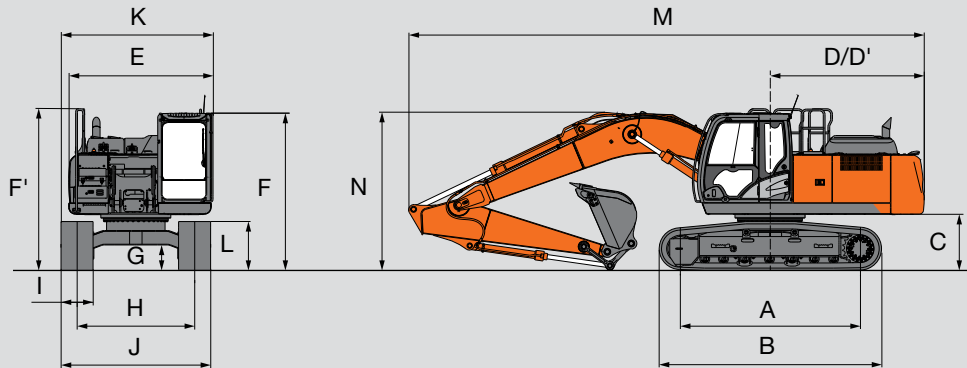

Unit: ft-in (mm)

	ZX210LC-6
A Distance between tumblers	12' 0" (3,660)
B Undercarriage length	14' 8" (4,460)
*C Counterweight clearance	3' 3" (980)
D Rear-end swing radius	9' 6" (2,890)
D' Rear-end length	9' 6" (2,890)
E Overall width of upperstructure	8' 11" (2,730)
F Overall height of cab	9' 8" (2,950)
F' Overall height of handrail	9' 11" (3,030)
*G Min. ground clearance	1' 6" (450)
H Track gauge	7' 10" (2,390)
I Track shoe width	32" (800)
J Undercarriage width	10' 6" (3,190)
K Overall width	10' 6" (3,190)
*L Track height with triple grouser shoes	2' 11" (920)
M Overall length with arm 9' 7" (2.91 m)	31' 8" (9,660)
N Overall height of boom with arm 9' 7" (2.91 m)	9' 8" (2,940)

\* Excluding track shoe lug

WORKING RANGES

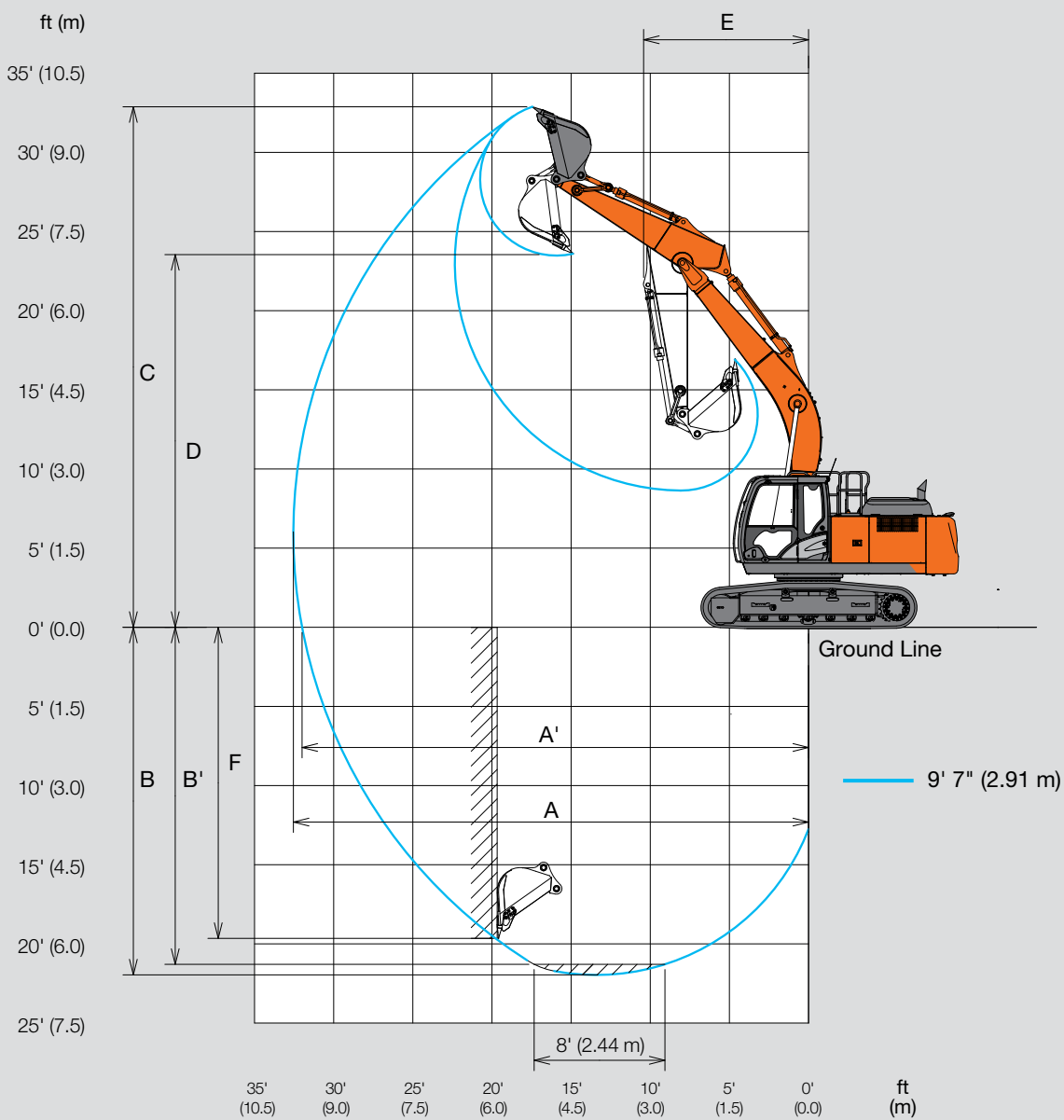

Unit: ft-in (mm)

	ZX210LC-6
Arm length	9' 7" (2.91 m)
A Max. digging reach	32' 7" (9,920)
A' Max. digging reach (on ground)	32' 0" (9,750)
B Max. digging depth	21' 11" (6,670)
B' Max. digging depth for 8' (2.44 m) level	21' 4" (6,490)
C Max. cutting height	32' 11" (10,040)
D Max. dumping height	23' 7" (7,180)
E Min. swing radius	10' 5" (3,180)
F Max. vertical wall digging depth	19' 8" (5,990)

Excluding track shoe lug

# MACHINE CAPACITIES

**Boldface type** indicates hydraulically limited capacity; lightface type indicates stability-limited capacities, in lb (kg). All machine capacities are based on ISO 10567 (with power boost). Ratings at bucket lift hook; machine equipped with standard counterweight and standard gauge; and situated on firm, uniform supporting surface. Total load includes weight of cables, hook, etc. Figures do not exceed 87% of hydraulic capacities or 75% of weight needed to tip machine.



A: Load radius  
B: Load point height  
C: Machine capacity

With counterweight 10,692 lb (4,850 kg), 9' 7" (2.91 m) arm, 1,468 lb (666 kg) bucket, and 32" (800 mm) triple grouser shoes

## ZX210LC-6

Rating over-front Rating over-side or 360 degrees Unit: lb (kg)

Conditions	Load point height ft (m)	Load radius									
		5' (1.5 m)		10' (3.0 m)		15' (4.5 m)		20' (6.0 m)		25' (7.5 m)	
Boom 18' 8" (5.68 m) Arm 9' 7" (2.91 m) Counterweight 10,692 lb (4,850 kg)	20' (6.0 m)							<b>10,110</b> <b>(4,580)</b>	<b>10,110</b> <b>(4,580)</b>		
	15' (4.5 m)					<b>12,920</b> <b>(5,860)</b>	<b>12,920</b> <b>(5,860)</b>	<b>11,210</b> <b>(5,080)</b>	<b>11,210</b> <b>(5,080)</b>	<b>10,470</b> <b>(4,740)</b>	7,970 (3,610)
	10' (3.0 m)					<b>16,990</b> <b>(7,700)</b>	<b>16,990</b> <b>(7,700)</b>	<b>13,050</b> <b>(5,910)</b>	11,180 (5,070)	<b>11,190</b> <b>(5,070)</b>	7,760 (3,510)
	5' (1.5 m)					<b>20,760</b> <b>(9,410)</b>	16,450 (7,460)	<b>14,920</b> <b>(6,760)</b>	10,660 (4,830)	11,950 (5,420)	7,520 (3,410)
	0 (ground)			<b>9,860</b> <b>(4,470)</b>	<b>9,860</b> <b>(4,470)</b>	<b>22,680</b> <b>(10,280)</b>	15,850 (7,180)	<b>16,180</b> <b>(7,330)</b>	10,300 (4,670)	11,750 (5,320)	7,330 (3,320)
	-5' (-1.5 m)	<b>10,950</b> <b>(4,960)</b>	<b>10,950</b> <b>(4,960)</b>	<b>19,370</b> <b>(8,780)</b>	<b>19,370</b> <b>(8,780)</b>	<b>22,630</b> <b>(10,260)</b>	15,680 (7,110)	<b>16,370</b> <b>(7,420)</b>	10,140 (4,590)	11,700 (5,300)	7,290 (3,300)
	-10' (-3.0 m)	<b>21,080</b> <b>(9,560)</b>	<b>21,080</b> <b>(9,560)</b>	<b>29,760</b> <b>(13,490)</b>	<b>29,760</b> <b>(13,490)</b>	<b>20,710</b> <b>(9,390)</b>	15,820 (7,170)	<b>14,960</b> <b>(6,780)</b>	10,230 (4,640)		
	-15' (-4.5 m)			<b>22,680</b> <b>(10,280)</b>	<b>22,680</b> <b>(10,280)</b>	<b>15,880</b> <b>(7,200)</b>	<b>15,880</b> <b>(7,200)</b>				





# EQUIPMENT

● : Standard equipment ○ : Optional equipment

ENGINE	
Aftertreatment device	●
Air cleaner double filters	●
Alternator 50 A	●
Auto idle system	●
Auto shutdown control	●
Cartridge-type engine oil filter	●
Cartridge-type fuel main filter	●
Cold fuel resistance valve	●
ConSite OIL (sensor)*	●
DEF/AdBlue® tank inlet strainer and extension filler	●
DEF/AdBlue® tank	●
Dry-type air filter with evacuator valve (with air filter restriction indicator)	●
Dustproof indoor net	●
ECO/PWR/HP mode control	●
Electrical fuel feed pump	●
Engine oil drain coupler	●
Expansion tank	●
Fan guard	●
Fuel cooler	●
Fuel prefilter with water separator	●
Isolation-mounted engine	●
Radiator, oil cooler, and intercooler	●

HYDRAULIC SYSTEM	
Auto power lift	●
ConSite OIL (sensor)*	●
Control valve with main relief valve	●
High mesh full flow filter	●
Pilot filter	●
Power boost	●
Suction filter	●
Swing dampener valve	●
Two extra ports for control valve	●
Variable relief valve for crusher	●
Work mode selector	●

\* Engine oil and hydraulic oil monitoring sensor.

CAB	
All-weather sound- suppressed steel cab	●
AM-FM radio	●
Ashtray	●
Auto control air conditioner	●
AUX function lever (attachment)	●
AUX terminal and storage	●
Cigarette lighter 24 V	●
CRES V (center pillar reinforced structure) cab	●
Drink holder with hot & cool function	●
Electric double horn	●
Engine shutoff switch	●
Equipped with reinforced, tinted (green color) glass windows	●
Evacuation hammer	●
Floor mat	●
Footrest	●
Front window washer	●
Glove compartment	●
Hot and cool box	●
Intermittent windshield wipers	●
Key cylinder light	●
LED room light with door courtesy	●
Lever auto-locking function	●
Motion alarm with cancel switch (conforms to SAE J994: 2014)	●
OPG top guard Level I (ISO 10262: 1998) compliant cab	●
Pilot-control shutoff lever	●
Power outlet 12 V	●
Rain guard (without OPG front guard)	●
Rear tray	●
Retractable seat belt 3 in.	●
ROPS (ISO 12117-2: 2008 ) compliant cab	●
Rubber radio antenna	●
Seat: air suspension seat with heater	●
Seat adjustment part: backrest, armrest, height and angle, slide forward/back	●
Short wrist control levers	●
Sun visor (multiuse front or side and rear window)	●
Smartphone holder	●
Transparent roof with slide curtain	●
USB power supply	●
Windows on front, upper, lower, and left side can be opened	●
2 speakers	●
4 fluid-filled elastic mounts	●

MONITOR SYSTEM	
Alarms: overheat, engine warning, engine oil pressure, alternator, minimum fuel level, hydraulic filter restriction, air filter restriction, work mode, SCR system trouble, etc.	●
Alarm buzzers: overheat, engine oil pressure, SCR system trouble, etc.	●
Display of meters: water temperature, hour, fuel rate, clock, DEF/AdBlue® rate, etc.	●
Other displays: work mode, auto-idle, glow, rearview monitor, operating conditions, etc.	●
32-language selection	●

LIGHTS	
Additional boom LED light with cover	●
Additional cab roof front LED lights	●
LED lights for camera (side and rearview camera)	●
2 working LED lights	●

UPPERSTRUCTURE	
Aerial Angle® (270-degree view camera system)	●
Batteries 2 x 126 Ah	●
Battery disconnect switch	●
Body top handrail	●
Counterweight 10,692 lbs. (4,850 kg)	●
Fuel level float	●
Hydraulic oil level gauge	●
Lockable fuel refilling cap	●
Lockable machine covers	●
Lockable toolbox	●
Platform handrail	●
Rearview mirror (right and left)	●
Skid-resistant plates and handrails	●
Swing parking brake	●
Undercover	●
Utility space	●

● : Standard equipment ○ : Optional equipment

**UNDERCARRIAGE**

Bolt-on sprocket	●
Reinforced track links with pin seals	●
Shoe: 32" (800 mm) triple grouser	●
Travel direction mark on track frame	●
Travel motor covers	●
Travel parking brake	●
Upper and lower rollers	●
3 track guards (each side) and hydraulic track adjuster	●
4 tie-down brackets	●

**FRONT ATTACHMENTS**

Arm 9' 7" (2.91 m)	●
Boom 18' 8" (5.68 m)	●
Casted bucket link A	●
Centralized lubrication system	●
Dirt seal on all bucket pins	●
Flanged pin	●
HN bushing	●
Reinforced bucket link B	●
Reinforced resin thrust plate	●
WC (tungsten-carbide) thermal spraying	●

**ATTACHMENTS**

Attachment basic piping	●
-------------------------	---

**MISCELLANEOUS**

ConSite	○
Global e-Service	●
Onboard information controller	●
Standard tool kit	●

Standard and optional equipment may vary by country, so please consult your Hitachi dealer for details.

Net engine power is with standard equipment, including air cleaner, exhaust system, alternator, and cooling fan, at test conditions specified per ISO 9249:2007. No derating is required up to 6,600 ft (2,000 m) altitude.

Specifications and design subject to change without notice. Wherever applicable, specifications are in accordance with SAE standards. Except where otherwise noted, these specifications are based on units with 9' 7" (2.91 m) arms; 41" (1,030 mm), 1,455 lb (660 kg) buckets; 10,692 lb (4,850 kg) counterweights; full fuel tanks; 165 lb (75 kg) operators, and a ZX210LC-6 unit with 32" (800 mm) triple grouser shoes.



# HITACHI

Reliable solutions



REPUTATIONS ARE  
**BUILT ON IT.**

With manufacturing facilities in Banshu, Ryugasaki, Tierra, Hitachinaka, and Tsuchiura, Japan, and the U.S. corporate office and campus in Newnan, Georgia, Hitachi Construction Machinery Americas Inc. (HCMA) has the experience and technology to design, engineer, manufacture, and service your Hitachi construction machinery. The HCMA team is securely poised as your go-to source in the North American and Latin American construction machinery markets.

Through our long-term commitment to maintaining a leadership position in technology, service, and support, HCMA supports an extensive network of independent, local dealers focused on providing you with knowledgeable and experienced sales, service, and parts personnel — all backed by dedicated HCMA support teams.

Your HCMA dealer has the resources, expertise, and personnel to work with you to ensure that you receive the most benefit from your Hitachi investment, utilizing carefully designed programs and services in conjunction with extensive digital resources. HCMA provides a totally focused approach to supporting you, your business, and your Hitachi construction machinery.

Machines representative of global product. Options may not be available in all markets. Prior to operating this machine, including satellite communication system, in a country other than a country of its intended use, it may be necessary to make modifications to it so that it complies with the local regulatory standards (including safety standards) and legal requirements of that particular country. Please do not export or operate this machine outside the country of its intended use until such compliance has been confirmed. Please contact your Hitachi dealer in case of questions about compliance.