

# HITACHI

**ZW160-7 | ZW160PL-7** | Preliminary  
ZW-7 series

Reliable Solutions



## ZW160

### WHEEL LOADER

Model code: ZW160-7 | ZW160PL-7

Engine maximum power: 169 hp (126 kW)

Operating weight: 28,467–29,983 lb. (12,910–13,600 kg)

Bucket capacity: 2.6–4.7 yd<sup>3</sup> (2.0–3.6 m<sup>3</sup>)

\* Shown with optional equipment that may not be available in all markets

# SPECIFICATIONS

ENGINE	
Model	CUMMINS B4.5
Type	4 cycle water-cooled, direct injection
Aspiration	Turbocharger and intercooled
Aftertreatment	DPF+SCR system
No. of cylinders	4
Maximum power	
ECE R120 gross	169 hp (126 kW) at 2,000 min <sup>-1</sup> (rpm)
ISO 9249: 2007 net	166 hp (124 kW) at 2,000 min <sup>-1</sup> (rpm)
Rated power	
ISO 14396: 2002	165 hp (123 kW) at 2,200 min <sup>-1</sup> (rpm)
ISO 9249: 2007 net	163 hp (122 kW) at 2,200 min <sup>-1</sup> (rpm)
Maximum torque	
ISO 9249: 2007 net.....	755 Nm at 1,200 min <sup>-1</sup> (rpm)
Bore and stroke	4.2" x 4.9" (107 mm X 124 mm)
Piston displacement	273.4 cu.in (4.46 L)
Batteries	2 x 12 V
Air cleaner	Two element dry type with restriction indicator

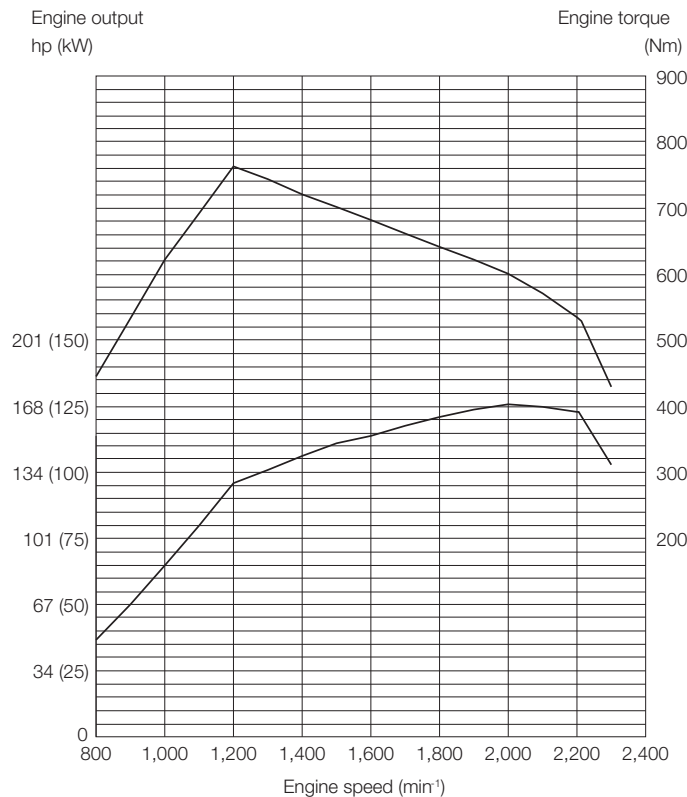

POWER TRAIN	
Transmission	Electrical-controlled 2 motor hydrostatic transmission with summation gear box, Gear box: Fixed gear ratio, powershift countershaft type
Cooling method	Forced circulation type
Travel speed* Forward/Reverse	
1st	8.1/8.1 mph (13/13 km/h) [8.1/8.1 mph (13/13 km/h)]
2nd	8.1/8.1 mph (13/13 km/h) [8.1/8.1 mph (13/13 km/h)]
3rd	12.4/12.4 mph (20/20 km/h) [12.4/12.4 mph (20/20 km/h)]
4th	24.2/24.2 mph (39/39 km/h) [24.2/24.2 mph (39/39 km/h)]

\*With 20.5 R25 (L3) tires  
[]: Data at Power Mode

AXLE AND FINAL DRIVE	
Drive system	Four-wheel drive system
Front and rear axle	Semi-floating
Front	Fixed to the front frame
Rear	Trunnion support
Reduction and differential gear	Two stage reduction with limited slip differential
Oscillation angle	Total 20° (+10°, -10°)
Final drives	Heavy-duty planetary, mounted inboard

TIRES	
Tire size	20.5 R25 (L3)

BRAKES	
Service brakes	Inboard mounted fully hydraulic 4 wheel wet disc brakes. Front and rear independent brake circuit, HST (Hydro Static Transmission) system provides additional hydraulic braking capacity
Parking brakes	Spring applied, hydraulically released, wet disc type

STEERING SYSTEM	
Type	Articulated frame steering
Steering angle	Each direction 40°; total 80°
Cylinders	Double-acting piston type
No. x Bore x Stroke	2 x 2.6" x 16.5" (2 x 65 mm x 419 mm)

HYDRAULIC SYSTEM	
<b>Arm and bucket are controlled by multifunction lever</b>	
Arm controls	Four position valve; Raise, hold, lower, float
<b>Bucket controls with automatic bucket return-to-dig control</b>	
Three position valve; Roll back, hold, dump	
<b>Main pump (Serve as steering pump)</b>	
Gear type	
Maximum flow	51.2 gal (194 L) /min at 2,200 min <sup>-1</sup> (rpm)
Maximum pressure	2,989 psi (20.6 MPa)
<b>Brake and fan and pilot oil pump</b>	
Gear type	
Maximum flow	11.9 gal (44.9 L) /min at 2,200 min <sup>-1</sup> (rpm)
Maximum pressure	2,248 psi (15.5 MPa)
<b>Hydraulic cylinders</b>	
ZW160-7	
Type	Double acting type
No. x Bore x Stroke	Arm: 2 x 4.9" x 30" (2 x 125 mm x 760 mm)
	Bucket: 1 x 5.9" x 19.5" (1 x 150 mm x 495 mm)
Filters	Full-flow 10 micron return filter in reservoir
ZW160PL-7	
Type	Double acting type
No. x Bore x Stroke	Arm: 2 x 4.9" x 30" (2 x 125 mm x 760 mm)
	Bucket: 2 x 4.3" x 39.6" (2 x 110 mm x 1,005 mm)
Filters	Full-flow 10 micron return filter in reservoir
<b>Hydraulic cycle times</b>	
ZW160-7	
Lift arm raise	6.4 s
Lift arm lower	3.8 s
Bucket dump	1.6 s
Total	11.8 s
ZW160PL-7	
Lift arm raise	6.8 s
Lift arm lower	3.6 s
Bucket dump	3.4 s
Total	13.8 s

\*Data at Power Mode

ENVIRONMENT	
<b>Engine Emissions</b>	
EPA Final Tier 4/EU stage V	
<b>Sound level</b>	
Sound level in cabin according to ISO 6396: 2008	67 LpA dB(A)
External sound level according To ISO 6395: 2008 and EU Directive 2000/14/EC	104 LwA dB(A)

SERVICE REFILL CAPACITIES	
Fuel tank	54.1 gal (205 L)
Engine coolant	5.3 gal (20 L)
Engine oil (Including oil pan)	4.3 gal (16 L)
Front axle differential and wheel hubs	6.6 gal (25 L)
Rear axle differential and wheel hubs	6.6 gal (25 L)
Hydraulic oil tank	21.2 gal (80 L)
DEF/AdBlue® tank	4.8 gal (18 L)

# SPECIFICATIONS

## DIMENSIONS AND SPECIFICATIONS ZW160-7

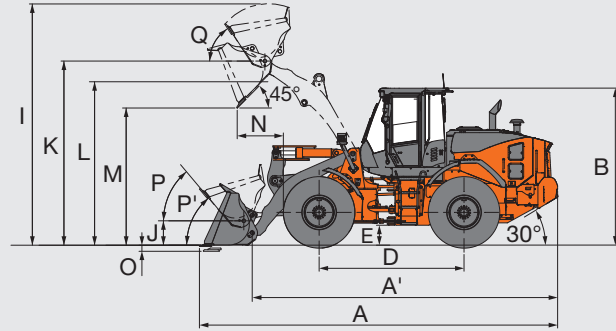
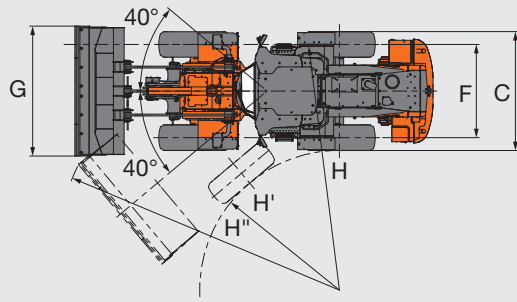

Bucket type		Standard arm					High-lift arm				
		General purpose									
		Weld-on teeth	Bolt-on cutting edge	Weld-on teeth	Bolt-on cutting edge	Bolt-on cutting edge	Weld-on teeth	Bolt-on cutting edge	Weld-on teeth	Bolt-on cutting edge	
Bucket capacity	ISO 7546: 1983 Heaped	yd <sup>3</sup> (m <sup>3</sup> )	2.9 (2.2)	2.9 (2.2)	3.1 (2.4)	3.1 (2.4)	4.7 (3.6)	2.6 (2.0)	2.6 (2.0)	2.9 (2.2)	2.9 (2.2)
	ISO 7546: 1983 Struck	yd <sup>3</sup> (m <sup>3</sup> )	2.4 (1.8)	2.4 (1.8)	2.6 (2.0)	2.6 (2.0)	4.1 (3.1)	2.1 (1.6)	2.1 (1.6)	2.4 (1.8)	2.4 (1.8)
A	Overall length	ft-in (mm)	25' 2" (7,670)	24' 8" (7,515)	25' 4" (7,720)	24' 10" (7,565)	25' 7" (7,810)	26' 7" (8,110)	26' 1" (7,955)	26' 9" (8,160)	26' 3" (8,005)
A'	Overall length (without bucket)	ft-in (mm)	21' 1" (6,420)	21' 1" (6,420)	21' 1" (6,420)	21' 1" (6,420)	21' 1" (6,420)	22' 8" (6,905)	22' 8" (6,905)	22' 8" (6,905)	22' 8" (6,905)
B	Overall height up to cab top	ft-in (mm)	10' 9" (3,280)	10' 9" (3,280)	10' 9" (3,280)	10' 9" (3,280)	10' 9" (3,280)	10' 9" (3,280)	10' 9" (3,280)	10' 9" (3,280)	10' 9" (3,280)
C	Width over tires outside tire	ft-in (mm)	8' 2" (2,500)	8' 2" (2,500)	8' 2" (2,500)	8' 2" (2,500)	8' 2" (2,500)	8' 2" (2,500)	8' 2" (2,500)	1' 8" (500)	8' 2" (2,500)
D	Wheel base	ft-in (mm)	9' 10" (3,000)	9' 10" (3,000)	9' 10" (3,000)	9' 10" (3,000)	9' 10" (3,000)	9' 10" (3,000)	9' 10" (3,000)	9' 10" (3,000)	9' 10" (3,000)
E	Ground clearance Minimum	ft-in (mm)	1' 5" (430)	1' 5" (430)	1' 5" (430)	1' 5" (430)	1' 5" (430)	1' 5" (430)	1' 5" (430)	1' 5" (430)	1' 5" (430)
F	Tread	ft-in (mm)	6' 4" (1,930)	6' 4" (1,930)	6' 4" (1,930)	6' 4" (1,930)	6' 4" (1,930)	6' 4" (1,930)	6' 4" (1,930)	6' 4" (1,930)	6' 4" (1,930)
G	Bucket width	ft-in (mm)	8' 4" (2,535)	8' 4" (2,535)	8' 4" (2,535)	8' 4" (2,535)	8' 10" (2,700)	8' 4" (2,535)	8' 4" (2,535)	8' 4" (2,535)	8' 4" (2,535)
H	Turning radius (centerline of outside tire)	ft-in (mm)	16' 8" (5,085)	16' 8" (5,085)	16' 8" (5,085)	16' 8" (5,085)	16' 8" (5,085)	16' 8" (5,085)	16' 8" (5,085)	16' 8" (5,085)	16' 8" (5,085)
H'	Turning radius to inside of tires	ft-in (mm)	9' 5" (2,870)	9' 5" (2,870)	9' 5" (2,870)	9' 5" (2,870)	9' 5" (2,870)	9' 5" (2,870)	9' 5" (2,870)	9' 5" (2,870)	9' 5" (2,870)
H''	Loader clearance radius, bucket in carry position	ft-in (mm)	19' 7" (5,980)	19' 6" (5,940)	19' 8" (5,995)	19' 6" (5,995)	20' 0" (6,100)	20' 3" (6,180)	20' 1" (6,130)	20' 4" (6,195)	20' 2" (6,150)
I	Overall operating height bucket full raise	ft-in (mm)	16' 6" (5,040)	16' 6" (5,040)	16' 9" (5,110)	16' 9" (5,110)	17' 11" (5,455)	17' 7" (5,350)	17' 7" (5,350)	17' 9" (5,415)	17' 9" (5,415)
J	Carry height of bucket pin at carry position	ft-in (mm)	1' 3" (385)	1' 3" (385)	1' 3" (385)	1' 3" (385)	1' 3" (385)	1' 3" (385)	1' 3" (385)	1' 3" (385)	1' 3" (385)
K	Height to bucket hinge pin, fully raised	ft-in (mm)	12' 7" (3,840)	12' 7" (3,840)	12' 7" (3,840)	12' 7" (3,840)	12' 7" (3,840)	13' 10" (4,210)	13' 10" (4,210)	13' 10" (4,210)	13' 10" (4,210)
L	Lift arm clearance at max lift	ft-in (mm)	11' 9" (3,570)	11' 8" (3,550)	11' 9" (3,570)	11' 8" (3,550)	11' 8" (3,550)	12' 11" (3,940)	12' 10" (3,920)	12' 11" (3,940)	12' 10" (3,920)
M	Dumping clearance 45 degree, full height	ft-in (mm)	8' 10" (2,690)	9' 2" (2,795)	8' 9" (2,655)	9' 1" (2,760)	8' 6" (2,590)	10' 2" (3,095)	10' 6" (3,200)	10' 0" (3,060)	10' 5" (3,165)
N	Reach, 45 degree dump, full height	ft-in (mm)	3' 9" (1,145)	3' 4" (1,010)	3' 11" (1,185)	3' 5" (1,045)	3' 12" (1,215)	4' 3" (1,300)	3' 10" (1,160)	4' 5" (1,335)	3' 11" (1,200)
O	Digging depth (horizontal digging angle)	ft-in (mm)	0' 3" (80)	0' 4" (105)	0' 3" (80)	0' 4" (105)	0' 4" (105)	0' 8" (205)	0' 9" (225)	0' 8" (205)	0' 9" (225)
P	Max. roll back at carry position	deg	46	46	46	46	46	47	47	47	47
P'	Max. roll back at ground level	deg	43	43	43	43	43	44	45	44	45
Q	Roll back angle at full height	deg	59	59	59	59	59	54	54	54	54

Bucket type		Standard arm					High-lift arm				
		General purpose									
		Weld-on teeth	Bolt-on cutting edge	Weld-on teeth	Bolt-on cutting edge	Bolt-on cutting edge	Weld-on teeth	Bolt-on cutting edge	Weld-on teeth	Bolt-on cutting edge	
Static tipping load ISO 14397-1: 2007 (Section 1-5) *	Straight .....lb (kg)	23,391 (10,610)	23,104 (10,480)	23,215 (10,530)	23,038 (10,450)	22,950 (10,410)	18,717 (8,490)	18,497 (8,390)	18,629 (8,450)	18,387 (8,340)	
	Full turn .....lb (kg)	20,305 (9,210)	20,040 (9,090)	20,150 (9,140)	19,952 (9,050)	19,886 (9,020)	16,160 (7,330)	15,961 (7,240)	16,094 (7,300)	15,851 (7,190)	
Breakout force	..... kN	105	99	99	94	77	103	97	98	92	
	..... lbf (kgf)	23,567 (10,690)	22,223 (10,080)	22,311 (10,120)	21,098 (9,570)	17,196 (7,800)	23,126 (10,490)	21,782 (9,880)	21,936 (9,950)	20,701 (9,390)	
Operating weight * (With ROPS/FOPS Cab)	lb (kg)	28,462 (12,910)	28,616 (12,980)	28,704 (13,020)	28,859 (13,090)	28,792 (13,060)	28,836 (13,080)	28,991 (13,150)	28,925 (13,120)	29,079 (13,190)	

Note: All dimensions, weight and performance data based on ISO 6746-1: 1987, ISO 7137: 2009 and ISO 7546: 1983

\*: Static tipping load and operating weight marked with\* include 20.5R25 (L3) tires (No ballast) with lubricants, full fuel tank and operator. Machine stability and operating weight depend on counterweight, tire size and other attachments.

### WEIGHT CHANGE

Option item		Operating weight lb (kg)	Tipping load lb (kg)		Overall width in (mm) (outside tire)	Overall height in (mm)	Overall length in (mm)
			Straight	Full turn			
Tires	20.5R25 (L3) VJTZ	+22 (+10)	+22 (+10)	+22 (+10)	±0	-0.2 (-5)	+0.2 (+5)
Belly guard		+154 (+70)	+88 (+40)	+88 (+40)	±0	±0	±0

### BUCKET SELECTION GUIDE

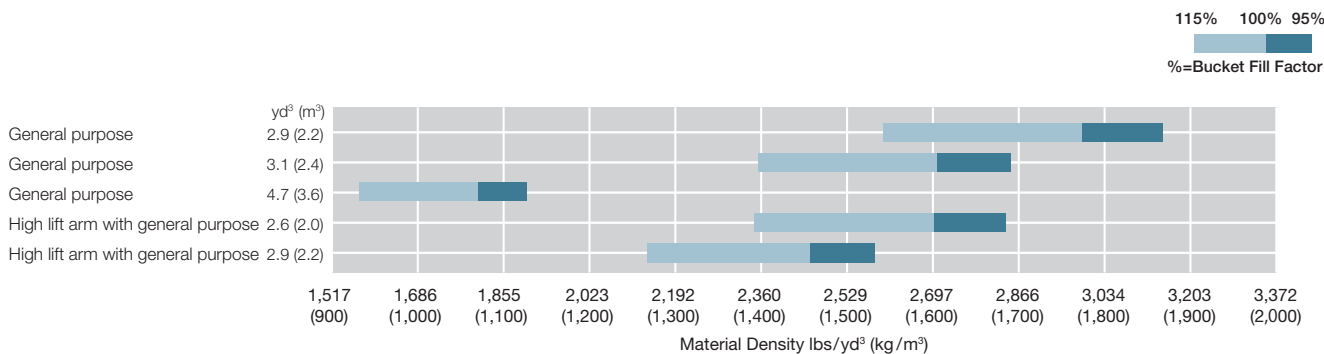

# SPECIFICATIONS

## DIMENSIONS AND SPECIFICATIONS ZW160PL-7

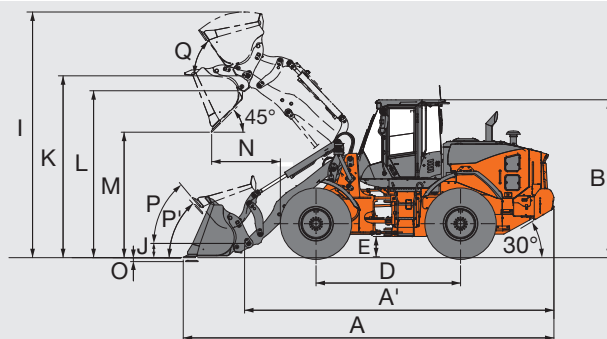
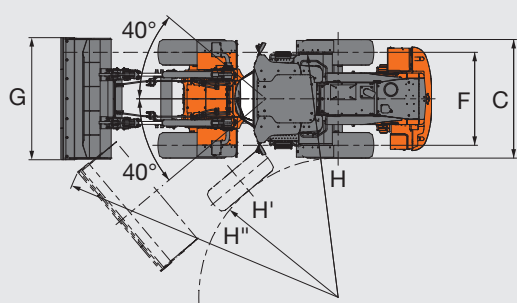

Bucket type		General purpose				
		Weld-on teeth	Bolt-on cutting edge	Weld-on teeth	Bolt-on cutting edge	
Bucket capacity	ISO 7546: 1983 Heaped	yd <sup>3</sup> (m <sup>3</sup> )	2.7 (2.1)	2.7 (2.1)	2.9 (2.2)	2.9 (2.2)
	ISO 7546: 1983 Struck	yd <sup>3</sup> (m <sup>3</sup> )	2.4 (1.8)	2.4 (1.8)	2.5 (1.9)	2.5 (1.9)
A	Overall length	ft-in (mm)	25' 12" (7,915)	25' 6" (7,765)	25' 12" (7,920)	25' 6" (7,760)
A'	Overall length (without bucket)	ft-in (mm)	21' 6" (6,565)	21' 6" (6,565)	21' 6" (6,565)	21' 6" (6,565)
B	Overall height up to cab top	ft-in (mm)	10' 9" (3,280)	10' 9" (3,280)	10' 9" (3,280)	10' 9" (3,280)
C	Width over tires outside tire	ft-in (mm)	8' 2" (2,500)	8' 2" (2,500)	8' 2" (2,500)	8' 2" (2,500)
D	Wheel base	ft-in (mm)	9' 10" (3,000)	9' 10" (3,000)	9' 10" (3,000)	9' 10" (3,000)
E	Ground clearance Minimum	ft-in (mm)	1' 5" (430)	1' 5" (430)	1' 5" (430)	1' 5" (430)
F	Tread	ft-in (mm)	6' 4" (1,930)	6' 4" (1,930)	6' 4" (1,930)	6' 4" (1,930)
G	Bucket width	ft-in (mm)	8' 4" (2,535)	8' 4" (2,535)	8' 4" (2,535)	8' 4" (2, 535)
H	Turning radius (centerline of outside tire)	ft-in (mm)	16' 8" (5,085)	16' 8" (5,085)	16' 8" (5,085)	16' 8" (5,085)
H'	Turning radius to inside of tires	ft-in (mm)	9' 5" (2,870)	9' 5" (2,870)	9' 5" (2,870)	9' 5" (2,870)
H''	Loader clearance radius, bucket in carry position	ft-in (mm)	19' 10" (6,055)	19' 9" (6,010)	19' 10" (6,055)	19' 9" (6,010)
I	Overall operating height bucket full raise	ft-in (mm)	17' 4" (5,280)	17' 4" (5,280)	17' 5" (5,320)	17' 5" (5,320)
J	Carry height of bucket pin at carry position	ft-in (mm)	1' 3" (390)	1' 3" (390)	1' 3" (390)	1' 3" (390)
K	Height to bucket hinge pin, fully raised	ft-in (mm)	13' 0" (3,975)	13' 0" (3,975)	13' 0" (3,975)	13' 0" (3,975)
L	Lift arm clearance at max lift	ft-in (mm)	12' 1" (3,690)	12' 0" (3,665)	12' 1" (3,690)	12' 0" (3,665)
M	Dumping clearance 45 degree, full height	ft-in (mm)	8' 8" (2,650)	9' 0" (2,755)	8' 8" (2,645)	9' 1" (2,760)
N	Reach, 45 degree dump, full height	ft-in (mm)	4' 8" (1,415)	4' 2" (1,280)	4' 8" (1,420)	4' 2" (1,275)
O	Digging depth (horizontal digging angle)	ft-in (mm)	0' 4" (105)	0' 5" (125)	0' 4" (105)	0' 5" (125)
P	Max. roll back at carry position	deg	47	47	47	47
P'	Max. roll back at ground level	deg	44	45	44	45
Q	Roll back angle at full height	deg	53	53	53	53
Bucket weight		lb (kg)	2,094 (950)	2,249 (1,020)	2,094 (950)	2,227 (1,010)
Static tipping load ISO 14397-1: 2007(Section 1-5) *	Straight	lb (kg)	21,341 (9,680)	21,098 (9,570)	21,539 (9,770)	21,341 (9,680)
	Full turn	lb (kg)	18,431 (8,360)	18,188 (8,250)	18,607 (8,440)	18,409 (8,350)
Breakout force		kN	105	100	104	101
		lbf (kgf)	23,523 (10,670)	22,509 (10,210)	23,413 (10,620)	22,597 (10,250)
Operating weight * (With ROPS/FOPS Cab)		lb (kg)	29,851 (13,540)	30,005 (13,610)	29,829 (13,530)	29,983 (13,600)

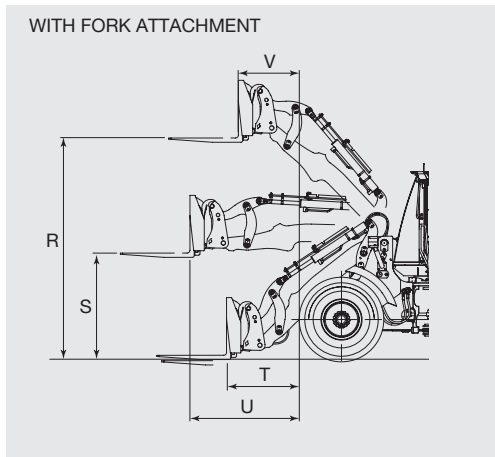

Attachment type		Fork
R	Max. stacking height	12' 4" (3,750)
S	Height of fork at maximum reach	5' 12" (1,820)
T	Reach at ground level	4' 1" (1,245)
U	Max. reach	6' 2" (1,875)
V	Reach at max. stacking height	3' 7" (1,080)
Static tipping load	Straight	15,058 (6,830)
	Full 40 degree turn	13,051 (5,920)
Max. payload per EN 474-3, 80 %		10,450 (4,740)
Max. payload per EN 474-3, 60 %		7,826 (3,550)
Fork tine length		4' 0" (1,220)
Operating weight *		28,903 (13,110)

Note: \*: Static tipping load and operating weight marked with\* include 20.5R25 (L3) tires (No ballast) with lubricants, full fuel tank and operator. Machine stability and operating weight depend on counterweight, tire size and other attachments.

### WEIGHT CHANGE

Option item	Operating weight lb (kg)	Tipping load lb (kg)		Overall width in (mm) (outside tire)	Overall height in (mm)	Overall length in (mm)
		Straight	Full turn			
Tires	20.5R25 (L3) VJ TZ	+22 (+10)	+22 (+10)	±0	-0.2 (-5)	+0.2 (+5)
Belly guard		+154 (+70)	+88 (+40)	±0	±0	±0

### BUCKET SELECTION GUIDE

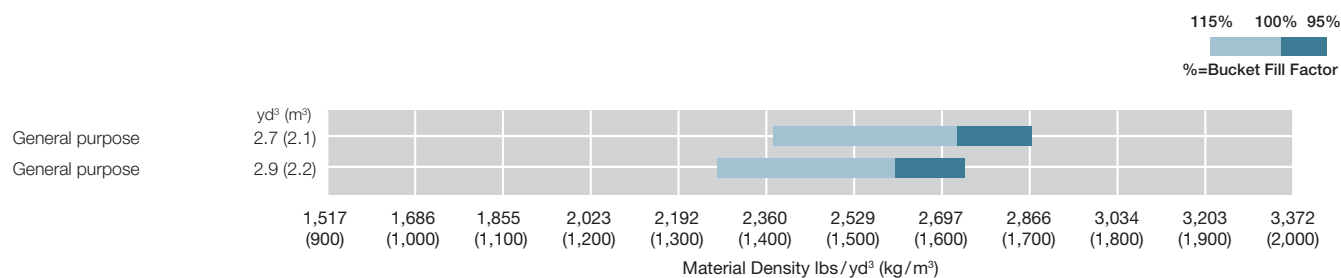

# EQUIPMENT

●: Standard equipment ○: Optional equipment

ENGINE	ZW160-7	ZW160PL-7
Aftertreatment device	●	●
Aftertreatment manual regeneration inhibit switch	●	●
Aftertreatment manual regeneration switch	●	●
Air filter double elements	●	●
Air intake		
Pre-cleaner (sy-klone type)	●	●
Pre-cleaner (Turbo II)	○	○
Anti-clogging radiator (wide fin pitch)	●	●
Automatic reversible cooling fan with heat sensing	●	●
Cartridge-type engine oil filter	●	●
Cartridge-type fuel main filter	●	●
Cartridge-type fuel pre-filter (with water separator function)	●	●
Coolant reservoir sight gauge	●	●
DEF/AdBlue® tank with magnet adapter	●	●
Engine auto shut-down control system	●	●
Engine oil remote drain	●	●
Fan guard	●	●

BRAKE SYSTEM	ZW160-7	ZW160PL-7
Front and rear independent brake circuit	●	●
Inboard mounted fully hydraulic 4 wheel wet disc	●	●
Spring-applied/Hydraulic-released parking brake	●	●

HYDRAULIC SYSTEM	ZW160-7	ZW160PL-7
Bucket auto leveler (automatic return to dig control)	●	●
Control lever lock switch	●	●
Dual lift arm auto leveler and kickout system	●	●
Electric control lever		
for 3 spools control valve		
MF lever and Proportional switch for 3rd function	●	●
Hydraulic filters	●	●
Lift arm float system	●	●
Quick coupler piping and switch	●	●
Reservoir sight gauge	●	●
Ride control system (OFF-AUTO type)	●	●
Work mode selector	●	●

CAB	ZW160-7	ZW160PL-7
Adjustable steering column with POP-UP	●	●
Auto control air conditioner		
Pre-cleaner for air conditioner	○	○
with double intake filter	●	●
Bluetooth® integrated DAB+radio, hands-free calling	●	●
Camera and monitor		
AERIAL ANGLE (Side and rear view camera)	○	○
Rear view camera and monitor	●	●
Coat hook	●	●
Evacuation hammer	●	●
Front/rear defroster	●	●
Glove compartment	●	●
LED room light	●	●
Payload checker with tip-off function	●	–
Rear obstacle detection system	○	○
Rear view mirrors		
Inside (1)	●	●
Standard outside mirrors	●	●
Premium Outside (heated, 2) electrical adjustment with proximity	○	○
Retractable seat belt, 3.0 in (76 mm)	●	●
ROPS (ISO 3471: 2008), FOPS (ISO 3449: 2008 LEVEL II): multi-plane isolation mounted for noise , vibration reduction	●	●
Rubber floor mat	●	●
Seat		
Heavy duty air suspension seat equipped with horizontal suspension headrest and heater: fabric, high back, adjustable for damper, inclination of the seat, seat depth, weight-height, fore-aft position, reclining angle, armrest angle, headrest height and angle, lumbar support	●	●
Seat belt reminder	●	●
Steering system		
Wheel steering	●	●
Storage		
Cup holder	●	●
Document holder	●	●
Hot and cool box	●	●
Seatback pocket	●	●
Smartphone and Tablet device holder	●	●
Sunscreen roller type	●	●
Textured steering wheel with spinner knob	●	●
Tinted safety glass		
Front windshield: laminated	●	●
Others: tempered	●	●
USB power supply	●	●
Windshield washer front and rear	●	●
Windshield wipers front and rear	●	●
2 speakers	●	●
8 inch sub monitor	●	●



●: Standard equipment ○: Optional equipment

MONITORING SYSTEM	ZW160-7	ZW160PL-7
Gauge: coolant temperature, fuel level, transmission oil temperature	●	●
Indicator lights: clearance lights, control lever lock, fuel level, high beam, parking brake, preheat, turn signals, work lights, fan reverse indicator, seat belt indicator	●	●
Indicator on multifunction monitor: F-N-R shift position, gear shift position, clock, DEF alarm indicator, DEF level gauge, ECO indicator, forward/reverse selector switch indicator, hold display, hour meter, odometer, battery volt, speedometer, tachometer, transmission auto-shifting indicator, Warning lights: air filter restriction, brake oil low pressure, communication system error, discharge warning, engine oil low pressure, engine warning, hydraulic oil level, low steering oil pressure, overheat, transmission warning	●	●
Indicator on sub monitor: payload checker (excluding PL), dual auto-leveler indicator rear obstacle detection and warning system (optional)	●	●
38 languages selection	●	●

ELECTRICAL SYSTEM	ZW160-7	ZW160PL-7
Alternator (95 A)	●	●
Backup alarm	●	●
Battery disconnect switch	●	●
Large capacity batteries	●	●
Power outlet 12 V and 24 V	●	●

LIGHTS	ZW160-7	ZW160PL-7
Clearance lights	●	●
LED brake and tail lights	●	●
LED headlights	●	●
Rotating lamp	○	○
Turn signals with hazard switch	●	●
Work lights		
premium work light package 4 front, 2 rear on cab and 2 rear LED working lights	●	●

TIRES	ZW160-7	ZW160PL-7
20.5R25 (L3) VJT	●	●

MISCELLANEOUS	ZW160-7	ZW160PL-7
Articulation lock bar	●	●
Belly guard (bolt on type) (front/rear)	○	○
Bucket cylinder guard	○	○
Cab top rail		
Front rail on the cab top	●	●
Rear rail on the cab top	●	●
Counterweight, built-in	●	●
Drawbar with locking pin	●	●
Emergency steering	○	○
Fenders		
for 20.5 R25 (front and full covered rear fenders with mud flaps)	○	○
for 20.5 R25 (front and half covered rear fenders)	●	●
Global e-Service	●	●
Lift and tie down hooks	●	●
Lift arm		
High lift arm	○	–
Parallel lift arm	–	●
Standard lift arm	●	–
On board information controller	●	●
Anti-Vandalism		
Battery cover with locking bracket	●	●
Lockable engine cover	●	●
Lockable fuel refilling cap	●	●
Quick coupler	○	○
Radiator dust protection screen	○	○
Standard tool kit	●	●

POWER TRAIN	ZW160-7	ZW160PL-7
Approach speed control	●	●
Deceleration select switch	●	●
Differential		
LSD (limited slip differential, front and rear)	●	●
Driving speed limiter 12.4 mph (20 km/h)	○	○
Electrically controlled HST system	●	●
Forward/reverse lever	●	●
Forward/reverse selector switch	●	●
Power mode switch	●	●
Traction control switch	●	●
1st speed limited switch	●	●



# HITACHI

Reliable Solutions



REPUTATIONS ARE  
**BUILT ON IT.**

Hitachi Construction Machinery Americas Inc. is a leading provider of construction and mining machinery services and solutions in North and Latin America. Our manufacturing facilities are located in Banshu, Ryugasaki, Tierra, Hitachinaka, and Tsuchiura, Japan, while our U.S. corporate office is in Newnan, Georgia. Our experienced team of professionals is well-equipped to design, engineer, manufacture, and service your machinery.

Through our long-term commitment to maintaining a leadership position in technology, service, and support, we support an extensive network of independent, local dealers focused on providing you with knowledgeable and experienced sales, service, and parts personnel — all backed by our dedicated support teams.

Your Hitachi Construction Machinery Americas authorized local dealer has the resources, expertise, and personnel to work with you to ensure that you receive the most benefit from your investment. You can also utilize carefully designed programs and services in conjunction with extensive digital resources. Our focus is entirely on supporting you, your business, and your machinery.

If you are searching for a reliable partner for your construction machinery needs, we invite you to explore our offerings and experience the difference with Hitachi Construction Machinery Americas.

Machines representative of global product. Options may not be available in all markets. Prior to operating this machine, including satellite communication system, in a country other than a country of its intended use, it may be necessary to make modifications to it so that it complies with the local regulatory standards (including safety standards) and legal requirements of that particular country. Please do not export or operate this machine outside the country of its intended use until such compliance has been confirmed. Please contact your Hitachi Construction Machinery Americas authorized local dealer in case of questions about compliance. These specifications are subject to change without notice. Illustrations and photos show the standard models, and may or may not include optional equipment, accessories, and all standard equipment with some differences in color and features. Before use, read and understand the Operator's Manual for proper operation.

07/2023  
Global Pub#: KL-EN190-NA-US  
Printed in the USA

[hitachicm.us](http://hitachicm.us)