

FARMALL® UTILITY

FARMALL UTILITY



FARMALL UTILITY
A SERIES



FARMALL UTILITY
C SERIES



FARMALL UTILITY
U SERIES

CASE IH

CASE IH

FARMALL®

A REMARKABLE HISTORY
DRIVEN BY INNOVATION

It all started with a revolutionary design back in 1923, and over the years the Farmall tractors evolved to meet the operators' changing needs, on and off the farm still going strong today.

FIRST GENERATION: 1923 – 1939

THE BEGINNING OF THE FARMALL SUCCESS STORY

- These “all purpose” tractors could pull heavy harvesting and tillage machines, and plant and cultivate row crops.
- Front mounting of the cultivator was the key to success.
- Launched in 1931, the F series was designed for farmers with 200+ acres who needed a more powerful 3-plow tractor.
- The F series featured new technologies like PTO, 4-speed transmission, gasoline engines, foot-to-floor pedal control, and rubber tires.
- In 1936, the Farmall paint color changed from “battleship gray” to the trademark Harvester Red #50.



SECOND GENERATION: 1939 – 1954

THE FAMOUS LETTER SERIES

- IH launched the Letter series featuring A and B (small-sized), H (middle-sized) and M (large-sized) tractors.
- Raymond Loewy’s “Culti-Vision” design moved the operator to the right of the engine for improved visibility. This feature remained in production for 40 years.
- The Farmall Super M-TA featured a torque amplifier, enabling operators to shift between two gears on-the-go or under load – an industry first.
- The 2-point Fast-Hitch on Farmall Super C tractors made it easy to attach rear-mounted implements.



THIRD GENERATION: 1954 – 1958

THE FARMALL NUMBER SERIES

- To meet demand for more power in the field, the Farmall number series (100, 200, 300 and 400) now replaced the letter series.
- The 300 and 400 models featured the torque amplifier, plus ten forward and two reverse gears.



FOURTH GENERATION: 1958 – 1962

A NEW WORLD OF POWER

- The Farmall 460 was the smallest of the 6-cyl. tractors and the diesel version had a direct-start system built by International Harvester.
- From 1958 to 1963 the Farmall 560 tractors were one of the most popular models sold in the US. Farmers liked the smooth economical 6 cyl. engine, independent power take off and the Torque Amplifier.



FIFTH GENERATION: 1963 – 1966

TOTAL POWER

- The Farmall 706 and 806 were the first all-new tractor designs from International Harvester in nearly 30 years.
- The 806 was marketed as the world's most powerful and toughest all-purpose tractor, with the all new D361 engine.
- In 1965, the Farmall 1206 Turbo was the first 2WD row-crop tractor to exceed 100 hp.



SIXTH GENERATION: 1967 – 1974

NEW HEAVYWEIGHTS

- The Farmall 656 tractor featured a continuously variable hydrostatic transmission for precise matching of speed and power for any job.
- On Feb. 1, 1974, a Farmall 1066 was the 5,000,000th International Harvester tractor rolled off the assembly line. IH was the first tractor manufacturer in the world to claim this distinction.



SEVENTH GENERATION: 2003 – PRESENT

FARMALL REBORN

- In 2003, Case IH reintroduced the Farmall series with a line of compact tractors designed for small farms and residential acreage.
- In 2012, Case IH introduced Farmall A, B and C series – tractors that combined utility engineering with advanced technology.
- Case IH continues to build on the Farmall legacy with the release of Farmall utility 55A, 65A and 75A tractors in 2018. In 2020, Farmall utility 95A, 105A and 115A tractors entered the marketplace.



US FARMING STATS

	1920s	1930s	1940s	1950s	1960s	1970s	2000s
US Population	105,720,620	122,775,046	131,820,000	151,132,000	180,007,000	240,335,000	290,800,000+
Farm Population	31,614,269	30,455,350	30,840,000	25,058,000	15,635,000	9,712,000	2,150,000
Labor Force	27% farmers	21% farmers	18% farmers	12.2% farmers	8.3% farmers	4.6% farmers	1.6% farmers
Number of Farms	6,454,000	6,295,000	6,102,000	5,388,000	3,711,000	2,780,000	2,166,780
Average Acreage	148	157	175	216	303	390	440





FARMALL UTILITY SERIES TRACTORS

3 Series | Standard, Deluxe and Premium | 53–140 Engine HP*

PERFORMANCE. VERSATILITY. POWER.

You have to be ready for any task and you expect the same from your utility tractor. No matter the job, Farmall utility tractors are ready to work as hard as you do. With easy operation, reliable power, an exceptional operating environment and features that enhance productivity for any task, there's a Farmall utility tractor model that's perfect for your operation.

“Our experience with our Farmall utility tractors has been fantastic. We chose the Farmall because of the quality of the tractor, the weight of it, and overall ease of operating it. These tractors are maintenance-free, with economical operating. It's designed for the farmer, instead of looks and speed.”

Dallas Petty, Crossville, AL



FARMALL UTILITY

A Farmall for Everyone 6
 Transmission Options 9
 Choosing the Right Farmall Utility 10-11

SMALL UTILITY

Standard: 50A / 60A / 70A 12-15
 Standard: 55A / 65A / 75A 16-19
 Deluxe: 65C / 75C 20-23

MEDIUM UTILITY

Standard: 95A / 105A / 115A 24-27
 Deluxe: 90C / 100C / 110C / 120C 28-31
 Premium: 110U / 120U 32-35

LARGE UTILITY

Standard: 110A / 120A / 130A / 140A 36-39
 Specifications 40-44
 Attachments, Implements and Loaders 46-49

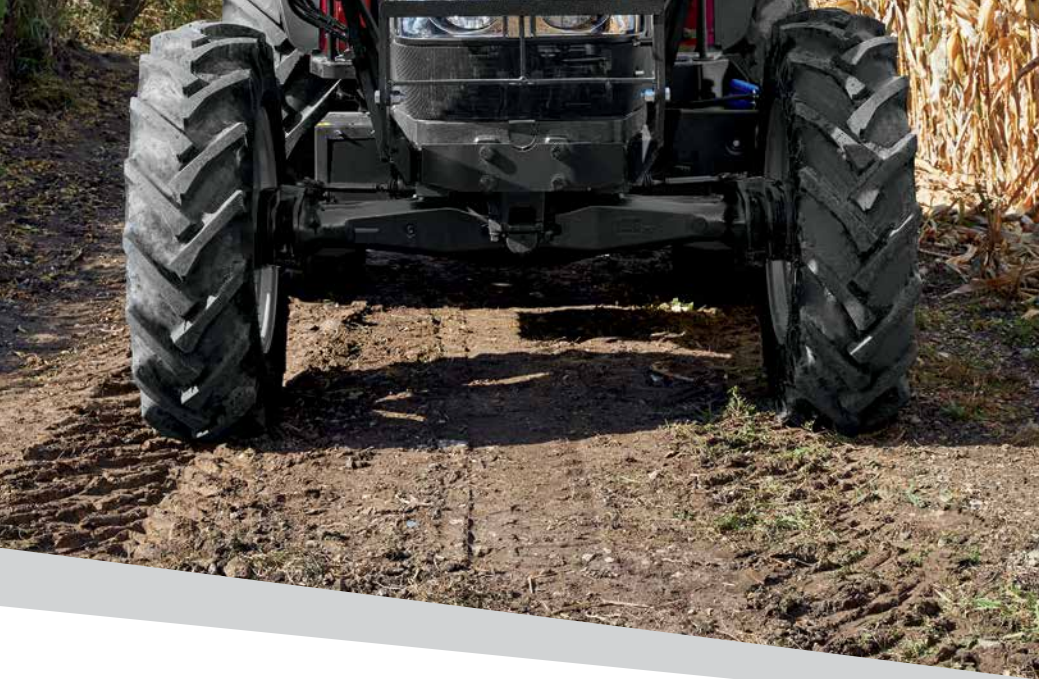

THERE'S A FARMALL FOR EVERYONE

More options – better value

UNMATCHED OPERATOR COMFORT

- Farmall tractors feature a spacious cab with ergonomically placed controls, easy-to-read instrument clusters and exceptional visibility – features that increase comfort and reduce fatigue.

HEAVIER WEIGHT AND DURABILITY

- Farmall tractors enable you to push, pull and lift more. That's because the tractor is engineered with heavier weights where it counts – the front and rear axles, final drive and the transmission housing.

NO REGENERATION REQUIRED

- Farmall tractors don't have a Diesel Particulate Filter. They meet all current emission requirements without regeneration – saving you time and money.

FEATURES THAT MATTER

- Farmall tractors offer more standard features than the competition. Features that deliver industry-leading performance and value – like a radio, two rear-hydraulic remotes and a high visibility roof panel come standard on select Farmall series tractors.

- Visibility through windshield
- Hidden area
- Visibility through roof panel

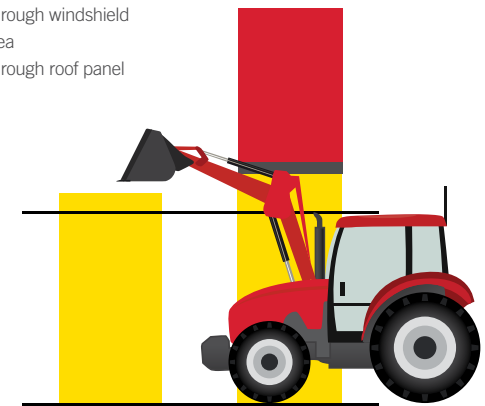



**FARMALL UTILITY
A SERIES**

STANDARD



**FARMALL UTILITY
C SERIES**

DELUXE



**FARMALL UTILITY
U SERIES**

PREMIUM



POWER THROUGH EVERY CHORE

Choose the transmission that works for you

Match your optimal transmission with your required horsepower range and ideal model.

TRANSMISSION	STANDARD (A SERIES)	DELUXE (C SERIES)	PREMIUM (U SERIES)
Mechanical Shuttle – 8×8	50A, 55A, 60A, 65A, 70A, 75A	N/A	N/A
Mechanical Shuttle – 12×12	95A*, 105A*, 115A*	N/A	N/A
Power Shuttle – 8×8	110A*, 120A*, 130A*, 140A*	75C	N/A
Power Shuttle – 16×8	110A*, 120A*, 130A*, 140A*	N/A	N/A
Power Shuttle – 12×12	55A*, 65A*, 75A*, 95A*, 105A*, 115A*	65C, 75C*, 90C*, 100C*, 110C*, 120C*	N/A
Power Shuttle – 24×24 Hi-Lo	N/A	90C, 100C, 110C, 120C	N/A
ActiveDrive 4 Semi-Power Shift – 16×16	N/A	N/A	110U*, 120U*

*Creeper available.



The Farmall utility A series (standard) is known for delivering high performance at a remarkable value.



The Farmall utility C series (deluxe) offers a hardworking, heavy-duty option with a full set of features.



The Farmall utility U series (premium) offers the ultimate operator environment with maximum versatility and comfort.

THE RIGHT SIZE FARMALL UTILITY TRACTOR FOR THE JOB

Identify the best utility tractor for your unique needs

6-foot operator



Find the right tractor for your operation with the **Right Red Tractor Tool** on caseih.com.

Non-Cab Height: 92.7–97.4 in.

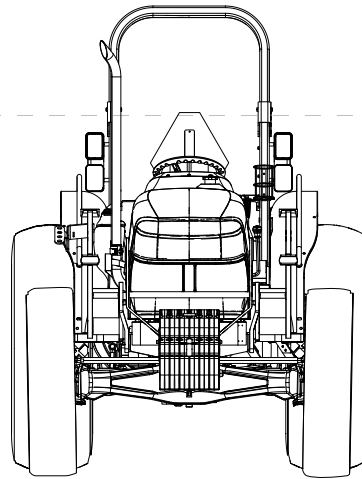

Cab Height: 100.2 in.
Non-Cab: 99.8 in.

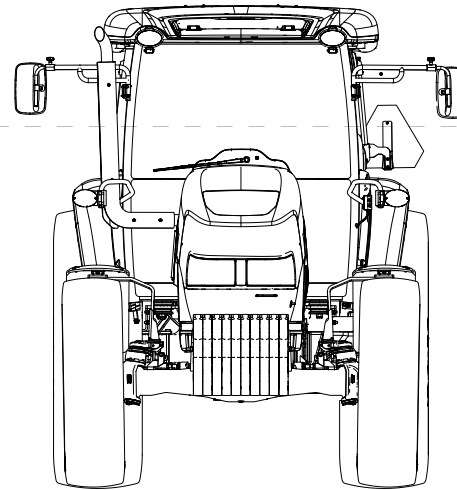

Cab Height: 98 in.
Non-Cab: 104.5 in.

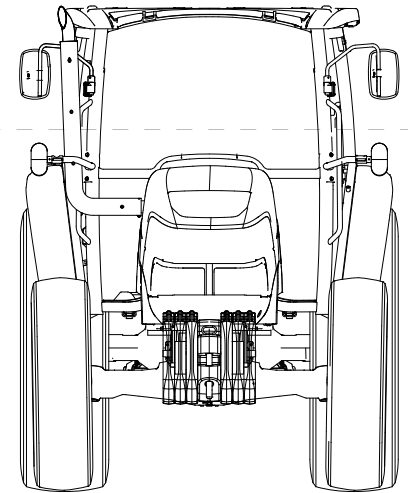

With Farmall utility tractors from 43 to 118 PTO horsepower, there's a hard-working, reliable model that's right for your operation.

Height dimensions are given using a standard size tire for each model series. Heights may vary depending on the specific tire size. This chart is intended to give you an overall impression of important specs that may be helpful when considering the purchase of a Farmall utility tractor.

STANDARD SMALL UTILITY

MODELS 50A/60A/70A

- 5,000 lb. class
- 2WD Wheelbase: 96.4 in.
- MFD Wheelbase: 97.6 in.
- Configurations:
 - Non-cab, 2WD/MFD
- Emissions Treatment
 - Internal exhaust gas recirculation (EGR) with diesel oxidation catalyst (DOC) and maintenance - free particulate matter catalyst (PM Cat).

STANDARD SMALL UTILITY

MODELS 55A/65A/75A

- 6,000 lb. class
- 2WD Wheelbase: 81.2 in.
- MFD Wheelbase: 81.8 in.
- Configurations:
 - 55A and 65A: Cab, 2WD/MFD
 - 75A: Cab or non-cab, 2WD/MFD
- Emissions Treatment
 - External cooled exhaust gas recirculation (CEGR) with diesel oxidation catalyst (DOC).
No regeneration.

DELUXE SMALL UTILITY

MODELS 65C/75C

- 7,000 lb. class
- 2WD Wheelbase: 86 in.
- MFD Wheelbase: 84 in.
- Configurations:
 - 65C: Cab, MFD
 - 75C: Cab or non-cab, 2WD/MFD
- Emissions Treatment
 - External cooled exhaust gas recirculation (CEGR) with diesel oxidation catalyst (DOC).
No regeneration.

Cab Height: 106 in.
Non-Cab: 103 in.

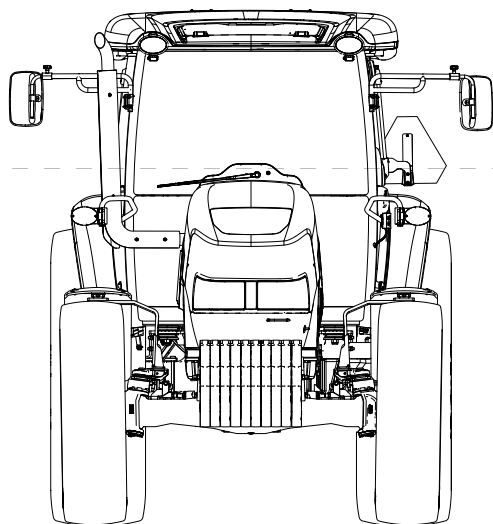

Cab Height: 102 in.
Non-Cab: 109 in.

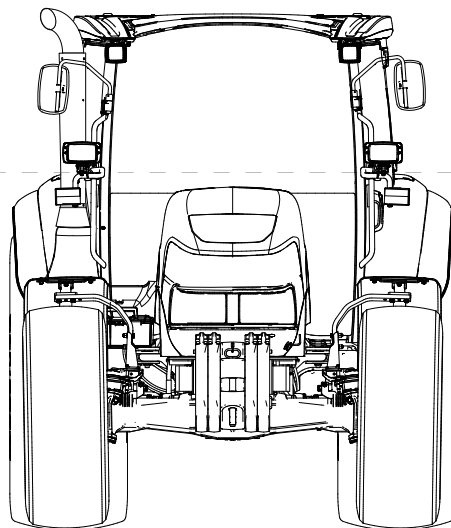

Cab Height: 107 in.

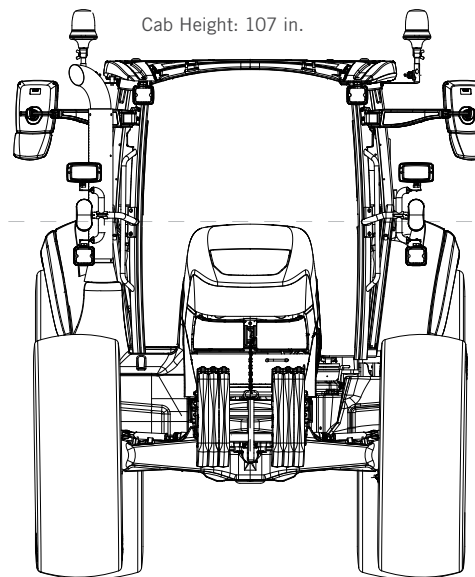

Cab Height: 110 in.
Non-Cab: 117.3 in.

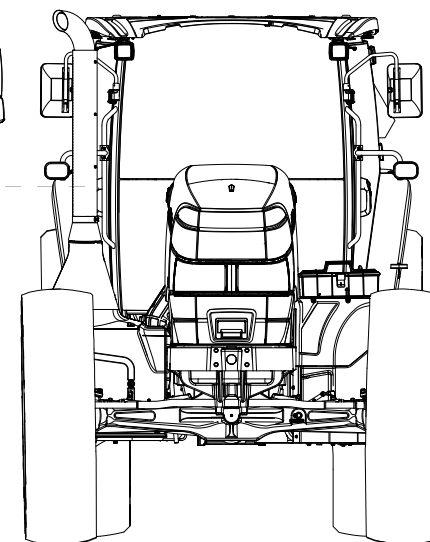

STANDARD MEDIUM UTILITY

MODELS 95A/105A/115A

- 8,000 lb. class
- 2WD Wheelbase: 91 in.
- MFD Wheelbase: 89 in.
- **Configurations:**
 - Cab or non-cab, 2WD/MFD
 - Low-profile/poultry
- **Emissions Treatment**
 - Selective catalytic reduction (SCR) with cooled exhaust gas recirculation (CEGR).
No regeneration.

DELUXE MEDIUM UTILITY

MODELS 90C/100C/110C/120C

- 8,000 lb. class
- 2WD Wheelbase: 92 in.
- MFD Wheelbase: 90 in.
- **Configurations:**
 - Cab or non-cab, 2WD/MFD
- **Emissions Treatment**
 - Selective catalytic reduction (SCR) with cooled exhaust gas recirculation (CEGR). *No regeneration.*
 - Selective catalytic reduction (SCR) with diesel oxidation catalyst (DOC). *No regeneration.* (with 24×24 Hi-Lo transmission).

PREMIUM MEDIUM UTILITY

MODELS 110U/120U

- 10,000 lb. class
- MFD Wheelbase: 93.7 in.
- **Configurations:**
 - Cab, MFD
- **Emissions Treatment**
 - Selective catalytic reduction (SCR) with cooled exhaust gas recirculation (CEGR).
No regeneration.

STANDARD LARGE UTILITY

MODELS 110A/120A/130A/140A PRO

- 11,000 lb. class
- 2WD Wheelbase: 96 in.
- MFD Wheelbase: 104 in.
- **Configurations:**
 - 110A: Cab, MFD
 - 120A: Cab or non-cab, MFD
 - 130A: Cab, 2WD/MFD
 - 140A: Cab, 2WD or non-cab MFD
- **Emissions Treatment**
 - Selective catalytic reduction (SCR) with diesel oxidation catalyst (DOC).
No regeneration.



STANDARD SMALL UTILITY

UTILITY A SERIES

FARMALL UTILITY 50A / 60A / 70A | 53 – 70 ENGINE HP*

The Farmall utility 50A, 60A and 70A models offer non-cab configurations loaded with value and the power you need to tackle any task.

STANDARD FEATURES:

- 3-cylinder, 2.2-L FPT engine (Tier 4 B/Final)
- 8x8 mechanical transmission
- One rear remote
- USB charging port

OPTIONAL FEATURES:

- Shiftable 540/540E PTO*
- Second rear remote

CONFIGURATIONS:

- Non-cab, 2WD/MFD



*See specs for details.



FARMALL UTILITY 50A/60A/70A



IT ALL BEGINS UNDER THE HOOD

- The Case IH FPT engine is **turbocharged and electronically controlled with a tunnel block design** to ensure ruggedness and easy maintenance without sacrificing power, efficiency or performance.
- An **electronic, high-pressure common rail fuel system** precisely meters fuel as power is demanded, delivering optimal performance and fuel efficiency.
- A simple **8x8 mechanical transmission** is easy to operate.
- **Optional shifttable 540/540E PTO** provides a fuel-saving option for less demanding applications.

EASY-TO-USE SHUTTLE

- The **push/pull design** makes directional changes intuitive.

DESIGNED FOR VERSATILITY

- A **column-mounted mechanical synchro-shuttle** provides easier shuttling and decreased cycle time during loader applications and greater reverse speed choices.
- A **sloped hood** gives you increased visibility to your work area, while a **no-tools-required hood latch** offers easy opening, with gas struts for support in open position.
- A **standard foldable ROPS** lets you keep working under low ceilings and in cramped spaces.
- Choose from either a **2WD or MFD front axle**, depending on the traction and maneuverability you need.

MORE COMES STANDARD

- **Flex link ends and telescopic stabilizers** make attaching implements easy.
- **Heavy-duty powertrain components** put more weight where you need it to deliver a heavy, durable tractor that matches demanding jobs.
- **Limited slip front differential** provides extra traction during slippery conditions.
- A **contoured seat** adjusts to each operator.
- **One rear remote** comes standard for easy hookup of hydraulic tools, with the option to add a second rear remote for even more versatility
- A **300-hour oil change interval** provides maximum uptime.
- **Standard USB charging port.**

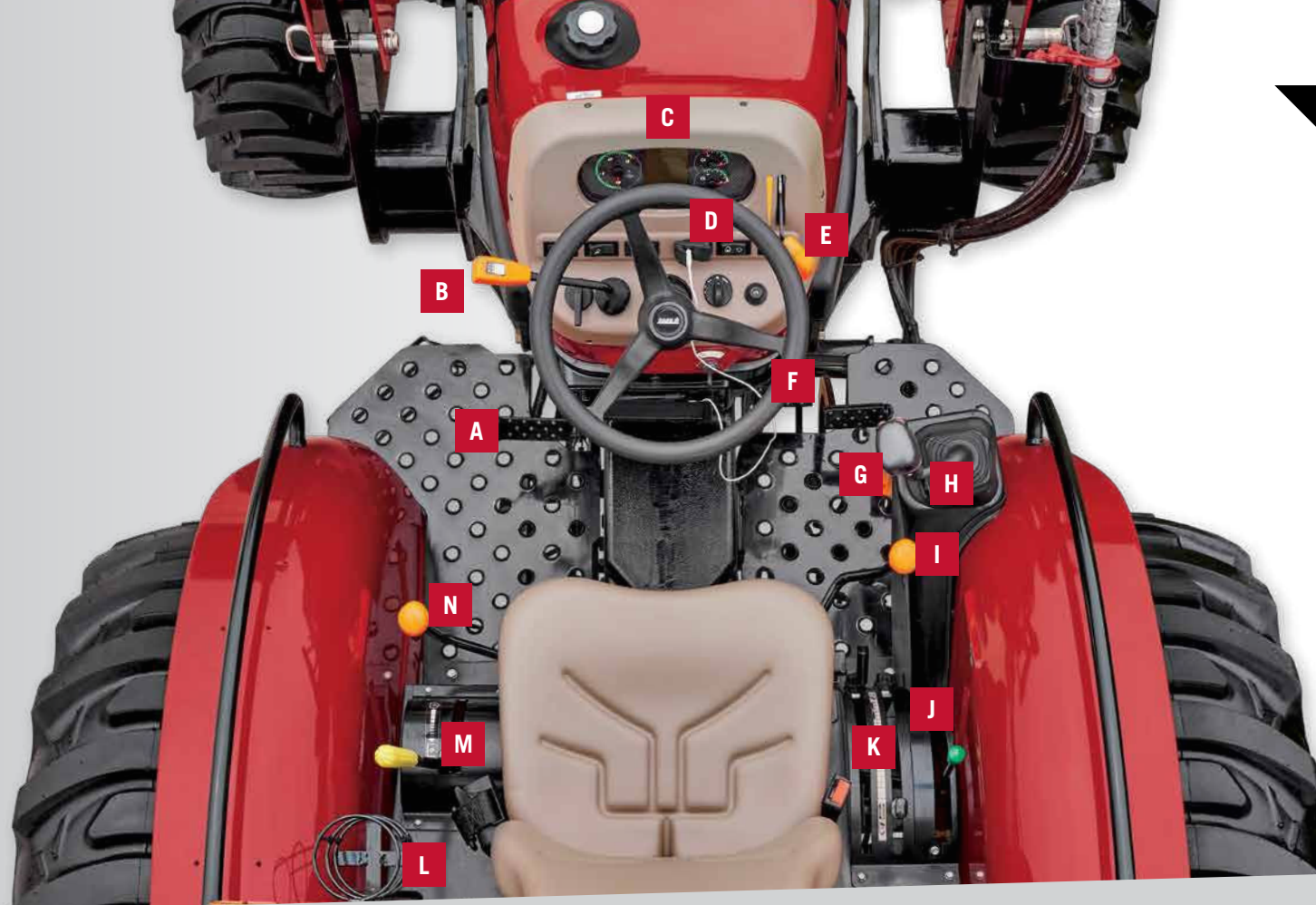

A Clutch Pedal

B Transmission Shuttle Shift Lever

C Backlit Automotive-Style Gauges
with a Central LCD Display:

Fuel Level, Tachometer and Engine Coolant Temperature

D USB Charger **Standard**

E Hand Throttle

F Brake Pedals

G Foot Throttle

H Loader Joystick

I Transmission Shift Lever: *H-Pattern Speed Selector - Gears 1-4*

J Remote Hydraulic Control Levers

K 3-Point Hitch Control Levers: *Position and Draft Control*

L Beverage Holder

M PTO Lever

N Range Selector: *High or Low*

Not Shown:

Parking Brake

MFD Engagement Lever MFD Configurations

Differential Lock Pedal



STANDARD SMALL UTILITY

UTILITY A SERIES

FARMALL UTILITY 55A / 65A / 75A | 54 – 74 ENGINE HP*

The Farmall utility 55A, 65A and 75A models offer cab configurations and more transmission options to handle tough jobs around the farmyard.

STANDARD FEATURES:

- 3-cylinder, 2.9-L FPT engine (Tier 4 B/Final)
- 8x8 mechanical transmission
- Two rear remotes
- High visibility roof panel (cab configurations)
- Radio ready (cab configurations)

OPTIONAL FEATURES:

- Instructor seat (cab configurations)
- Bluetooth® radio (cab configurations)
- 12x12 clutchless power shuttle or 12x12 with creeper option
- Shiftable 540/540E PTO*
- Third rear remote

CONFIGURATIONS:

- 55A and 65A: Cab, 2WD/MFD
- 75A: Cab or non-cab, 2WD/MFD



*See specs for details.



FARMALL UTILITY 55A/65A/75A

IT ALL BEGINS UNDER THE HOOD

- The Case IH FPT engine is **turbocharged and electronically controlled with a tunnel block design** to ensure ruggedness and easy maintenance without sacrificing power, efficiency or performance.
 - **No diesel particulate filter, diesel exhaust fluid or regeneration is required** to increase uptime and decrease operating costs — all while meeting Tier 4 B/Final engine emissions standards.
 - An **electronic, high-pressure common rail fuel system** precisely meters fuel as power is demanded, delivering optimal performance and fuel efficiency.
 - **Optional shifttable 540/540E PTO** provides a fuel-saving option for less demanding applications.

EASY-TO-USE SHUTTLE

- **The push/pull design makes directional changes intuitive.**



DESIGNED FOR VERSATILITY

- **Choose from either a simple 8x8 mechanical transmission or a 12x12 clutchless power shuttle transmission** that's ideal for loader work.
- **Column-mounted mechanical synchro-shuttle** provides easier shuttling and decreased cycle time during loader applications and greater reverse speed choices.
- A **sloped hood** gives you increased visibility to your work area, while a **no-tools-required hood latch** offers easy opening, with gas struts for support in open position.
- **Movable dynamic fenders** allow for improved turning radius and maneuverability.

MORE COMES STANDARD

- On cab models, a **standard high visibility roof panel** allows the operator to take on loader tasks — such as stacking bales — quickly and safely.
- **Heavy-duty powertrain components** put more weight where you need it to deliver a heavy, durable tractor that matches demanding jobs.
- **Tilt steering wheel adjustment** for improved operator comfort.
- Comfortably fit two adults in the cab with a **standard instructor seat** on cab configuration.
- **Standard radio ready** or choose the available Bluetooth radio option which allows you to listen to music or talk hands-free.
- **2 standard rear remotes.**
- A **600-hour oil change interval** provides maximum uptime.

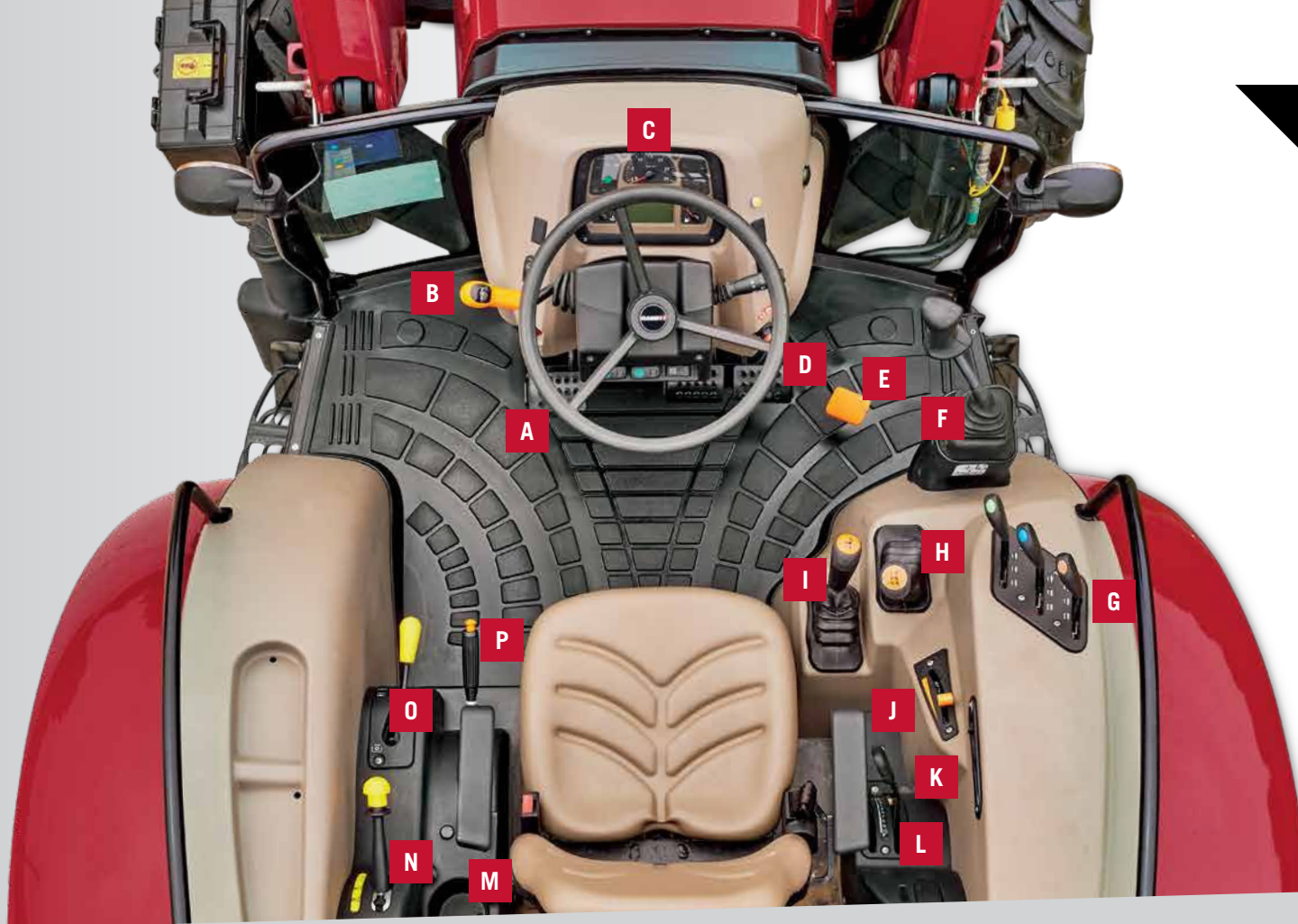

A Clutch Pedal

B Power Shuttle Control Lever

C Backlit Automotive-Style Gauges
with a Central LCD Display:

Fuel Level, Tachometer and Engine Coolant Temperature

D Brake Pedals

E Foot Throttle

F Loader Joystick

G Remote Hydraulic Control Levers

H Transmission Shift Lever: H-Pattern Speed Selector - Gears 1-4

I Range Selector 2 or 3 Ranges

J Hand Throttle

K Fast Raise/Lower Control

L 3-Point Hitch Control Levers: Position and Draft Control

M Beverage Holder

N 540 / 540E PTO Lever

O PTO Lever

P Parking Brake

Not Shown:

Steering Wheel Tilt Adjustment Pedal **Standard**

Optional Instructor Seat Cab Configurations

Radio Ready **Standard** Cab Configurations

High Visibility Roof Panel **Standard** Cab Configurations



DELUXE SMALL UTILITY

UTILITY C SERIES

FARMALL UTILITY 65C / 75C | 64 – 74 ENGINE HP*

A deluxe tractor package equipped with full power, comfort and features. Ideal for demanding livestock duties, heavy loader work, landscaping and municipality tasks.

STANDARD FEATURES:

- 4-cylinder, 3.4-L FPT engine (Tier 4 B/Final)
- 12x12 power shuttle transmission
- Two rear remotes
- Instructor seat (cab configurations)
- Bluetooth radio (cab configurations)

OPTIONAL FEATURES:

- 8x8 power shuttle transmission (75C only)
- 12x12 power shuttle transmission with creeper
- Shiftable 540/540E PTO*
- Third rear remote
- High visibility roof panel (cab configurations)

CONFIGURATIONS:

- 65C: Cab, MFD
- 75C: Cab or non-cab, 2WD/MFD



*See specs for details.



FARMALL UTILITY 65C/75C

POWER THROUGH EVERY CHORE

- The Case IH FPT engine is **turbocharged and electronically controlled with a tunnel block design** to ensure ruggedness and easy maintenance without sacrificing power, efficiency or performance.
- **No diesel particulate filter, diesel exhaust fluid or regeneration is required** to increase uptime and decrease operating costs — all while meeting Tier 4 B/Final engine emissions standards.
- An **electronic, high-pressure common rail fuel system** precisely meters fuel as power is demanded, delivering optimal performance and fuel efficiency.
- **Heavy-duty powertrain components** put more weight where you need it to deliver a heavy, durable tractor that matches demanding jobs.

EASY-TO-USE SHUTTLE

- The **push/pull design** makes **directional changes intuitive**.

PUSH, PULL & LIFT MORE

- Farmall C tractors are built for implements with **dual, engine-driven hydraulic pumps** that deliver performance where and when you need it.
- Connect implements quickly and easily with **two standard rear remotes**, and an optional third remote for added flexibility.
- **Standard 3-point hitch** pulls its weight with a 3,664-lb. lift capacity with telescopic stabilizers and right-link turnbuckle leveling.



DELUXE ACCOMMODATIONS

- A **large operator area** provides outstanding comfort along with ease of operation and exceptional visibility.
- **Tilt steering wheel adjustment** for improved operator comfort.
- An optional ergonomic, **loader joystick** integrates into the right-hand console for easy operation.
- Non-cab models feature a **vinyl seat with armrests and a foldable ROPS** for working areas with low overheads.
- Cab models feature a **standard instructor seat and Bluetooth radio**.
- **A hinged rear window opens completely and is supported by gas struts**, with a lower viewing window for increased visibility to the drawbar, 3-point hitch and remotes.

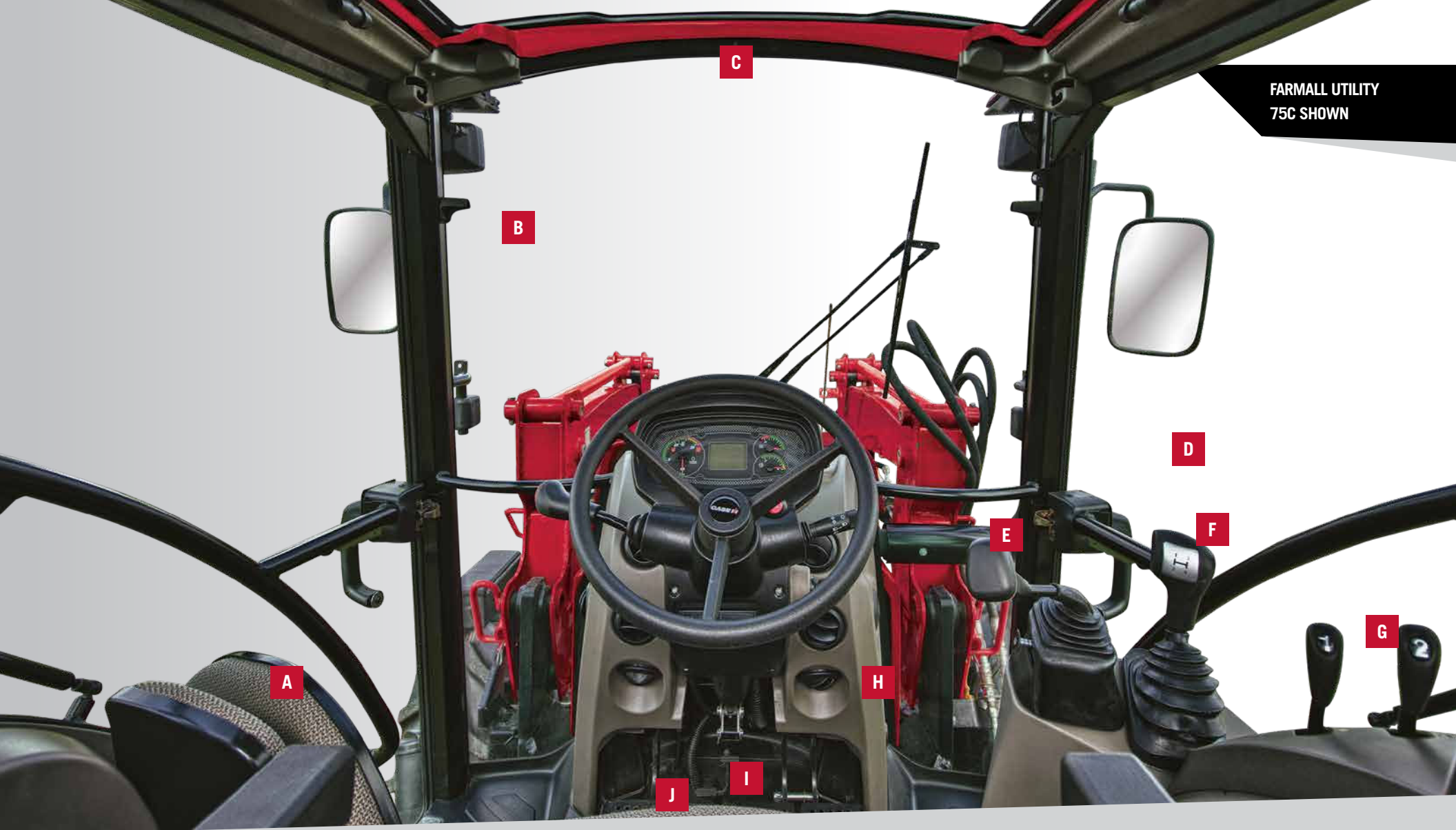

- A** Instructor Seat **Standard** Cab Configurations
- B** Curved Window Frame Increases Loader Visibility
- C** Optional High Visibility Roof Panel Cab Configurations
- D** Two Doors For Easy Accessibility
- E** Ergonomic Loader Joystick
- F** Transmission Shift Lever: H-Pattern Speed Selector - Gears 1-4

- G** Ergonomic, Simple-to-use Controls
- H** 10 Dashboard HVAC Vents
- I** Steering Wheel Tilt Adjustment Pedal **Standard**
- J** Air Suspension Seat with 15 Degree Swivel **Standard** Cab Configurations

Not Shown:

- Bluetooth Radio **Standard** Cab Configurations
- Retractable Sun Screen Covers Roof Panel and Upper Windshield
- Optional Monitor Bar



STANDARD MEDIUM UTILITY

UTILITY A SERIES

FARMALL UTILITY 95A / 105A / 115A | 97 – 120 ENGINE HP*

Efficient all-around chore tractor for small farms, rural estates, large mixed farms, and commercial or municipal applications.

STANDARD FEATURES:

- 4-cylinder, 3.4-L engine (Tier 4 B/Final)
- 12x12 power shuttle transmission (creeper-ready)
- Two rear remotes
- Instructor seat (cab configurations)
- High visibility roof panel (cab configurations)
- Bluetooth radio (cab configurations)

OPTIONAL FEATURES:

- 540/540E PTO*
- Third rear remote

CONFIGURATIONS:

- Cab or non-cab, 2WD/MFD
- Low-profile/poultry



*See specs for details.



**68.4 INCH
HEIGHT PERFECT
FOR POULTRY BARN**



FARMALL UTILITY 95A/105A/115A

POWER AND PERFORMANCE

- The Case IH FPT engine is **turbocharged and electronically controlled with a tunnel block design** to ensure ruggedness and easy maintenance without sacrificing power, efficiency or performance.
 - **No diesel particulate filter or regeneration is required.** Our Selective Catalytic Reduction (SCR) technology means increased uptime and decreased operating costs — all while meeting Tier 4 B/Final engine emissions standards.
 - An **electronic, high-pressure common rail fuel system** precisely meters fuel as power is demanded, delivering optimal performance and fuel efficiency.
 - Choose from either a **2WD or MFD front axle**, depending on the traction and maneuverability you need.
 - **Optional shifttable 540/540E PTO** provides a fuel-saving option for less demanding applications.

EASY-TO-USE SHUTTLE



- **The push/pull design makes directional changes intuitive.**

GO LOW-PROFILE

- **A low-profile/poultry configuration** is ideal for specialty operations where space and ground clearance are at a premium.
- An **industry-exclusive reversing engine fan** comes standard to help keep poultry farm operators running all day. Clean the grill with ease, with the press of a button.
- An **overall height of 68.4 in.** accommodates lower-clearance poultry houses.*
- An optional **creeper completion kit provides added precision** when you need it.

MORE STANDARD FEATURES FOR A GREAT RIDE

- The **12×12 clutchless power shuttle transmission** helps ensure ease of operation during loader work — and it's creeper-ready if you need added precision.
- **Heavy-duty powertrain components** put more weight where you need it to deliver a heavy, durable tractor that matches demanding jobs.
- **Tilt steering wheel adjustment** for improved operator comfort.
- On cab models, a **standard high visibility roof panel** allows the operator to safely take on loader tasks, while **four cab-mounted work lights** provide ample lighting at all hours.
- An **air suspension seat** ensures smooth, comfortable operation, while an ISO-mounted frame minimizes vibration and noise.
- Cab models feature a **standard instructor seat and Bluetooth radio.**

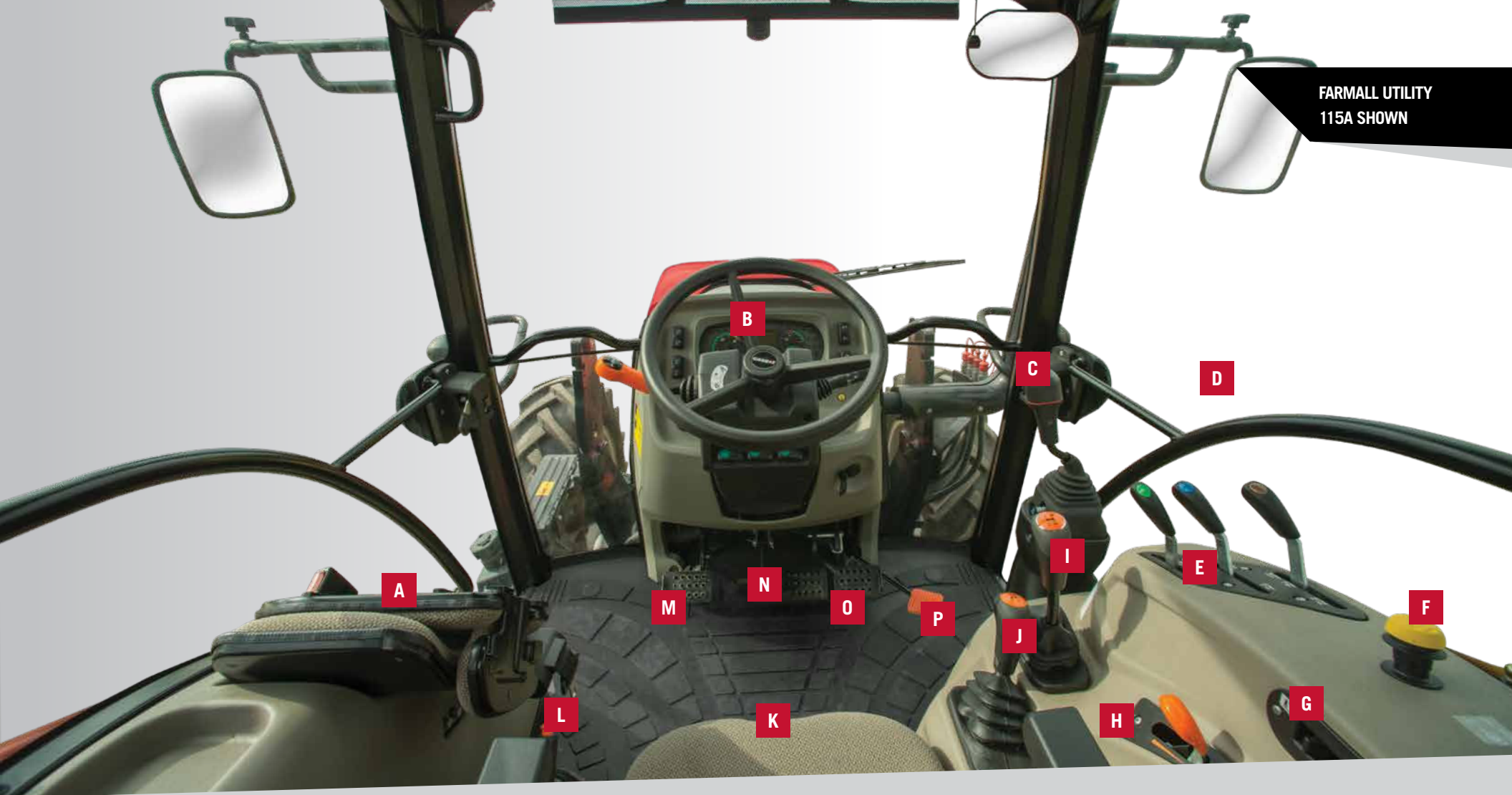

A Instructor Seat **Standard** Cab Configurations

B Backlit Automotive-Style Gauges
with a Central LCD Display:

Fuel Level, Tachometer and Engine Coolant Temperature

C Loader Joystick

D Two Doors For Easy Accessibility

E Remote Hydraulic Control Levers

F PTO Switch

G Fast Raise/Lower Control

H Hand Throttle

I Transmission Shift Lever: H-Pattern Speed Selector - Gears 1-4

J Range Selector Low, Medium or High

K Air Suspension Seat **Standard**

L Parking Brake

M Clutch Pedal

N Steering Wheel Tilt Adjustment Pedal **Standard**

O Brake Pedals

P Foot Throttle

Not Shown:

High Visibility Roof Panel **Standard** Cab Configurations

Bluetooth Radio **Standard** Cab Configurations



DELUXE MEDIUM UTILITY

UTILITY C SERIES

FARMALL UTILITY 90C / 100C / 110C / 120C | 86–117 ENGINE HP*

The Farmall utility 90C, 100C, 110C and 120C models feature full power, full comfort and full features, and they are ideal for demanding livestock duties, larger hay operations and heavy loader work.

STANDARD FEATURES:

- 4-cylinder, 3.4-L FPT engine (Tier 4 B/Final)
- 12×12 power shuttle transmission
- Two rear remotes
- Instructor seat (cab configurations)
- Radio (cab configurations)

OPTIONAL FEATURES:

- 12×12 power shuttle transmission with creeper
- 24×24 hi-lo transmission
- 540/1000 PTO*
- Third rear remote
- High visibility roof panel (cab configurations)

CONFIGURATIONS:

- Cab or non-cab, 2WD/MFD



*See specs for details.



FARMALL UTILITY 90C/100C/110C/120C

POWER THROUGH EVERY CHORE

- The Case IH FPT engine is **turbocharged and electronically controlled with a tunnel block design** to ensure ruggedness and easy maintenance without sacrificing power, efficiency or performance.
- **No diesel particulate filter or regeneration is required.** Our Selective Catalytic Reduction (SCR) technology means increased uptime and decreased operating costs — all while meeting Tier 4 B/Final engine emissions standards.
- An **electronic, high-pressure common rail fuel system** precisely meters fuel as power is demanded, delivering optimal performance and fuel efficiency.
- **Heavy-duty powertrain components** put more weight where you need it to deliver a heavy, durable tractor that matches demanding jobs.

EASY-TO-USE SHUTTLE

- The **push/pull design** makes directional changes intuitive.



PUSH, PULL & LIFT MORE

- Farmall C tractors are built for implements with **dual, engine-driven hydraulic pumps** that deliver performance where and when you need it.
- Connect implements quickly and easily with **two standard rear remotes** and an optional third remote for added flexibility.
- **Standard 3-point hitch** pulls its weight with a 4,339-lb. lift capacity with telescopic stabilizers and right-link turnbuckle leveling.

DELUXE ACCOMMODATIONS

- A **large operator area** provides outstanding comfort along with ease of operation and exceptional visibility. An **air suspension seat comes standard** on cab configurations.
- The optional, loader joystick is **integrated into the right-hand console** for easier operation and greater productivity.
- Non-cab models feature a **vinyl seat with armrests and a foldable ROPS** for working areas with low overheads.
- Cab models feature a **standard instructor seat and radio.**
- A **hinged rear window opens completely and is supported by gas struts**, with a lower viewing window for increased visibility to the drawbar, 3-point hitch and remotes.
- **24x24 hi-lo transmission features electro hydraulic shuttle** and electronic rear hitch controls on cab configurations.

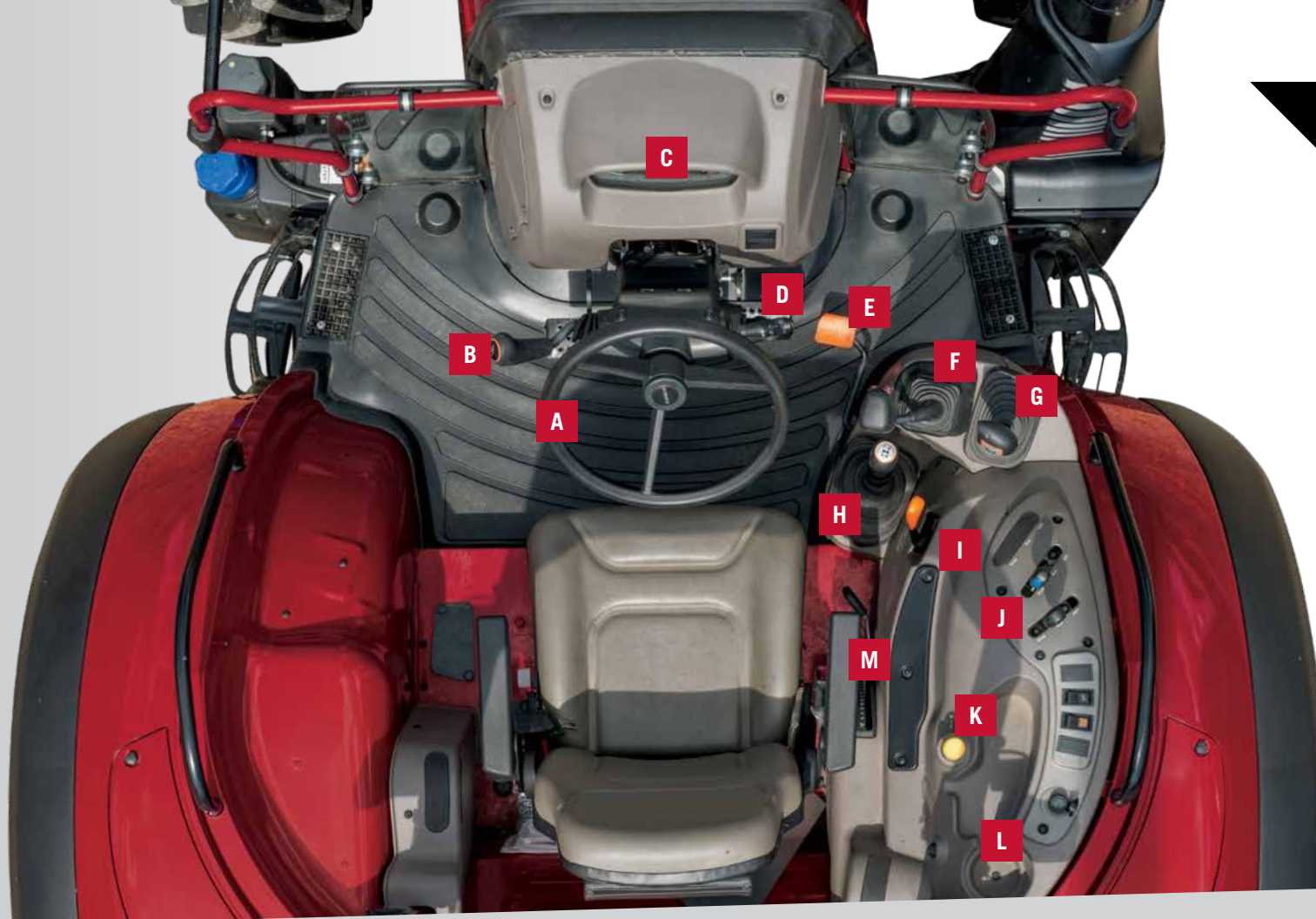

A Clutch Pedal

B Power Shuttle Control Lever

C Backlit Automotive-Style Gauges
with a Central LCD Display:

Fuel Level, Tachometer and Engine Coolant Temperature

D Brake Pedals

E Foot Throttle

F Loader Joystick

G Transmission Shift Lever: Hi/Lo Shift Integrated into
the Handle on 24×24 Models

H Range Selector with Parking Lock (or Choose
Hand Brake Option)

I Hand Throttle

J Remote Hydraulic Control Levers

K PTO Switch

L Beverage Holder

M 3-Point Hitch Control Levers: Position and Draft Control

Not Shown:

Air Suspension Seat with 15 Degree
Swivel **Standard** Cab Configurations

Instructor Seat **Standard** Cab Configurations

Radio **Standard** Cab Configurations

Optional High Visibility Roof Panel Cab Configurations



PREMIUM MEDIUM UTILITY

UTILITY U SERIES

FARMALL UTILITY 110U / 120U | 107 – 117 ENGINE HP*

The ultimate Farmall experience for a range of operations — from livestock and commercial hay productions to diversified farms. These heavy-duty, power packed utility tractors with high-capacity hydraulics are ideal for the most demanding chores.

STANDARD FEATURES:

- 4-cylinder, 3.4-L FPT engine (Tier 4 B/Final)
- 16x16 ActiveDrive 4 semi-powershift transmission
- Three mechanical rear remotes, two with configurable detents
- Instructor seat
- High visibility roof panel
- Bluetooth radio

OPTIONAL FEATURES:

- 16x16 ActiveDrive 4 semi-powershift transmission with creeper
- Auto Shift function, suspended cab, and suspended front axle
- Shiftable 540/540E/1000 PTO*

CONFIGURATIONS:

- Cab, MFD



*See specs for details.



FARMALL UTILITY 110U/120U

MAXIMUM POWER AND EFFICIENCY

- The Case IH FPT engine is **turbocharged and electronically controlled with a tunnel block design** to ensure ruggedness and easy maintenance without sacrificing power, efficiency or performance.
 - **No diesel particulate filter or regeneration is required.** Our Selective Catalytic Reduction (SCR) technology means increased uptime and decreased operating costs — all while meeting Tier 4 B/Final engine emissions standards.
 - An **electronic, high-pressure common rail fuel system** precisely meters fuel as power is demanded, delivering optimal performance and fuel efficiency.
 - **Heavy-duty powertrain components** put more weight where you need it to deliver a heavy, durable tractor that matches demanding jobs.
 - The **optional auto-PTO engagement feature** automatically engages or disengages based on a 3-point hitch set point, so your tractor is more efficient when operating equipment such as a finishing mower.

EASY-TO-USE SHUTTLE

- The **push/pull design makes directional changes intuitive.**



HANDLE THE MOST DEMANDING JOBS

- **Tandem hydraulic pumps** work independently for better efficiency and improved performance during heavy lifting.
- The **open-center, 21-gallons per minute, hydraulic system** features closed-center load-sensing remotes to safely power hydraulic motors.
- Power implements quickly and easily with **three standard rear remotes.**
- A **standard heavy-duty 3-point hitch** offers many of the settings and features found on larger tractors with telescopic stabilizers and dual turnbuckle leveling.
- Farmall utility U series tractors match the capacity of the **L103 loader.**

A PREMIUM RIDE

- A **spacious cab** and flat deck floor with ergonomically placed controls and deluxe features offer outstanding comfort along with ease of operation.
- A **standard high visibility roof panel** with an opening window allows the operator to see full-range loader operation.
- A **fully adjustable air-ride seat** comes standard to help make long days feel shorter.
- **Six work lamps and two wraparound headlights** illuminate your work area day or night.
- **Four rubber isolation mounts** reduce vibration and noise.
- An **optional suspended cab** delivers increased comfort, while an **optional suspended front axle** provides increased performance and a smoother ride.
- An ergonomic, **factory-installed loader joystick** is available and integrates into the right-hand console for easy operation.

FARMALL UTILITY
120C SHOWN

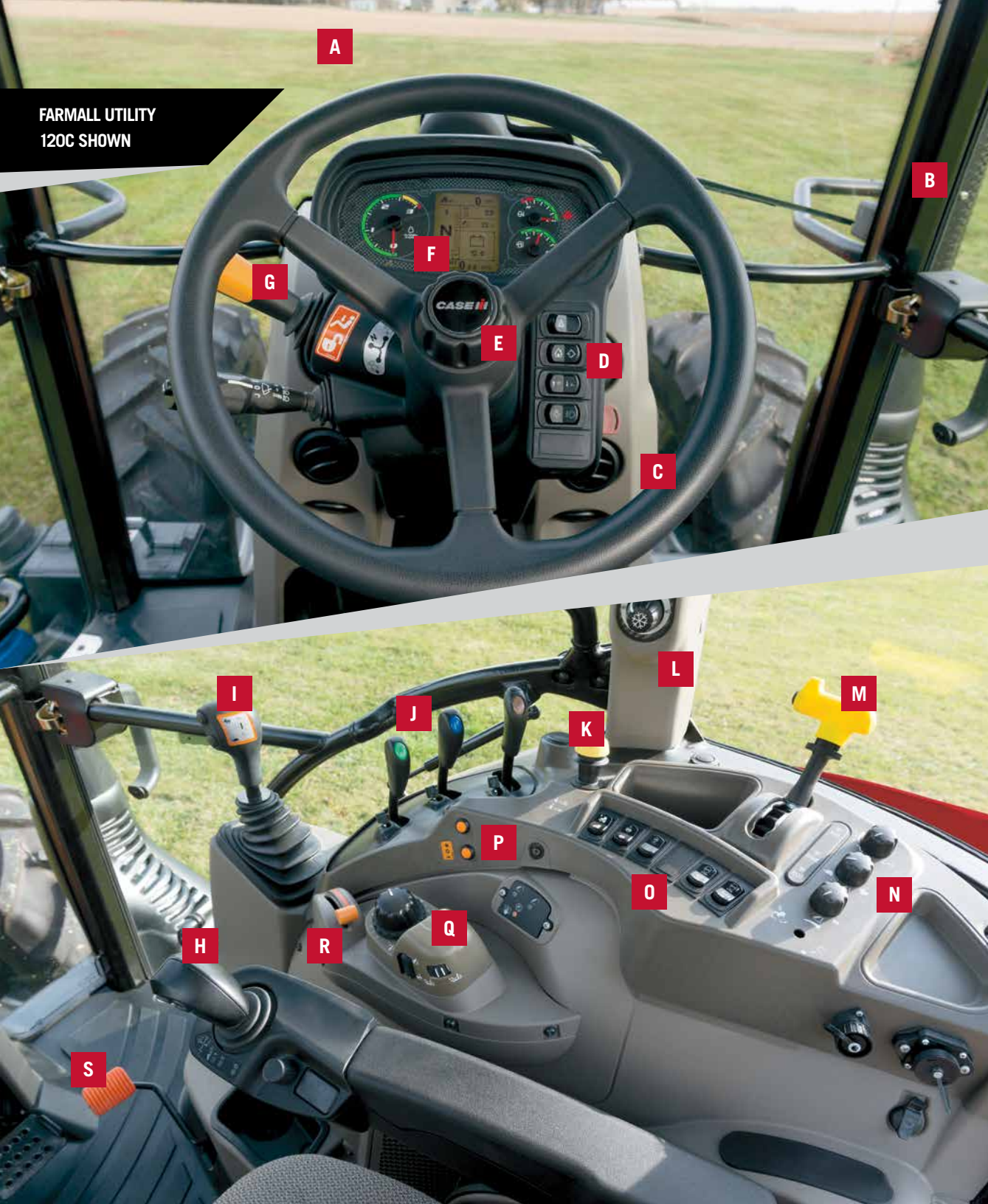

A Curved Window Frame Increases Loader Visibility

B Two Doors For Easy Accessibility

C 10 Dashboard HVAC Vents

D Ergonomic, Simple-to-use Electronic Controls

E Adjustable Steering Column Height

F Instrument Cluster Tilts with Steering Column

G Power Shuttle Control Lever

H Advanced Loader Joystick

I Range Selector with Parking Lock

J Remote Control Levers

K PTO Switch

L Electric Fan Speed Temperature Control

M PTO Speed Selection Lever

N Rear Hitch Control

O Electro-hydraulic Control Switches

P Electronic Transmission Shift Controls

Q Electronic Lift Controls

R Hand Throttle

S Foot Throttle

Not Shown:

Steering Wheel Tilt Adjustment Pedal **Standard**

Premium/Heated Air Suspension Seat **Standard**

Instructor Seat **Standard**

High Visibility Roof Panel **Standard**

Bluetooth Radio **Standard**

Optional Monitor Bar





STANDARD LARGE UTILITY

UTILITY A SERIES

FARMALL UTILITY PRO 110A / 120A / 130A / 140A | 110–140 ENGINE HP*

The multipurpose Farmall utility 110A, 120A, 130A, 140A tractors are tough, reliable and an excellent value.

STANDARD FEATURES:

- 4-cylinder, 4.5-L FPT engine (Tier 4 B/Final)
- 8x8 power shuttle transmission
- Two rear remotes
- Radio (cab configurations)

OPTIONAL FEATURES:

- 16x8 power shuttle with hi-lo gear selection
- Up to four remote valves
- Instructor seat (cab configurations)
- High visibility roof panel (cab configurations)

CONFIGURATIONS:

- 110A: Cab, MFD
- 120A: Cab or non-cab, MFD
- 130A: Cab, 2WD/MFD
- 140A: Cab, 2WD or non-cab, MFD



*See specs for details.



FARMALL UTILITY PRO 110A/120A/130A/140A

POWER THROUGH EVERY CHORE

- The Case IH FPT engine is **turbocharged and electronically controlled with a tunnel block design** to ensure ruggedness and easy maintenance without sacrificing power, efficiency or performance.
- **No diesel particulate filter or regeneration is required.** Our Selective Catalytic Reduction (SCR) technology means increased uptime and decreased operating costs — all while meeting Tier 4 B/Final engine emissions standards.
- An **electronic, high-pressure common rail fuel system** precisely meters fuel as power is demanded, delivering optimal performance and fuel efficiency.
- **Heavy-duty powertrain components** put more weight where you need it to deliver a heavy, durable tractor that matches demanding jobs.
- **3-point hitch with a capacity up to 7,200 lb.** — and you can connect implements quickly with two standard remotes.

EASY-TO-USE SHUTTLE

- The push/pull design makes **directional changes intuitive.**



SMOOTH SHIFTING

- Shift easily from forward to reverse with the **standard 8x8 clutchless power shuttle transmission.**
- The **optional 16x8 clutchless power shuttle transmission** with hi-lo gear selection in every range delivers maximum control.
- A **10:1 reduction creeper option** is also available — an ideal selection for specialty applications such as vegetable and fruit production.
- All controls are **easy to use and ergonomically placed** for simple operation.

COMFORTABLE AND CONVENIENT

- An **ISO-mounted cab** with a large operator platform helps reduce the impact of rough terrain.
- **Tilt steering wheel adjustment** for improved operator comfort.
- A **curved window frame** increases loader visibility at a lower base investment, while an **optional high visibility roof panel** provides superior forward visibility to take on loader tasks — such as stacking bales — with ease.
- The optional, loader joystick is **integrated into the right-hand console** for easier operation and greater productivity.
- A **contoured seat adjusts to each operator**, while an optional air suspension seat with 15-degree swivel is also available.
- **Standard radio** on cab configuration.

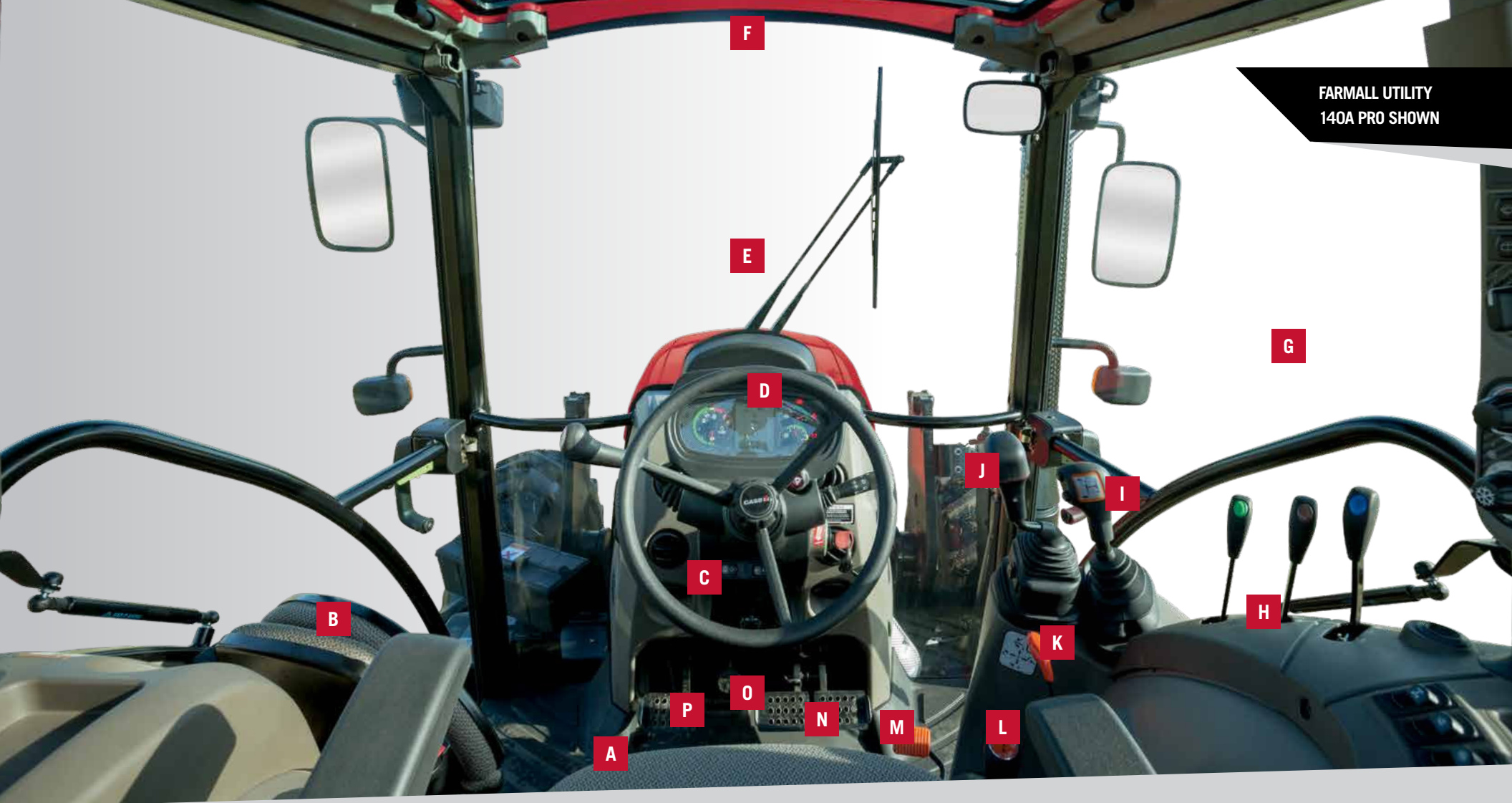

A Optional Air Suspension Seat with 15-degree Swivel

B Optional Instructor Seat

C 10 Dashboard HVAC Vents

D Backlit Automotive-Style Gauges
with a Central LCD Display:

Fuel Level, Tachometer and Engine Coolant Temperature

E Curved Window Frame Increases Loader Visibility

F Optional High Visibility Roof Panel

G Two Doors For Easy Accessibility

H Ergonomic, Simple-to-use Controls

I Transmission Shift Lever: Optional Hi/Lo Shift Integrated
into the Handle on 16x8 Models

J Loader Joystick

K Hand Throttle

L Range Selector High or Low

M Foot Throttle

N Brake Pedals

O Steering Column Tilt Adjustment Pedal **Standard**

P Clutch Pedal

Not Shown:

Radio **Standard** Cab Configurations

Parking Brake

PTO Switch

MODEL	FARMALL 50A	FARMALL 55A	FARMALL 60A	FARMALL 65A	FARMALL 65C
<i>SERIES CLASSIFICATION</i>	STANDARD				DELUXE
Operator Station	Non-cab	Cab	Non-cab	Cab	Cab
Traction	2WD/MFD				MFD
ENGINE					
Type	3-cylinder, Tier 4 B/Final, FPT turbocharged & aftercooled				4-cylinder, Tier 4 B/Final, FPT turbocharged
Displacement	2.2 L	2.9 L	2.2 L	2.9 L	3.4 L
Engine HP ¹	53	54	60	64	64
PTO HP ¹	45	43	51	51	50
Rated Engine RPM	2,600	2,300	2,600	2,300	
TRANSMISSION / PTO					
Standard	8×8 Mechanical shuttle (dry clutch)				12×12 Power shuttle (wet clutch)
Optional	N/A	12×12 Power shuttle (wet clutch) or 12×12 with creeper	N/A	12×12 Power shuttle (wet clutch) or 12×12 with creeper	N/A
Differential Lock	Mechanical				
MFD Engagement	Mechanical	Electrohydraulic	Mechanical	Electrohydraulic	
PTO Speed (Standard / Optional)	540 / 540E	540 / 540/540E	540 / 540E	540 / 540/540E	540 / 540/540E
AXLES					
Front	2WD or MFD with limited slip				MFD with limited slip
Rear	Flange				
HYDRAULICS / HITCH					
Type	Open center				
Rear Remotes (Standard / Optional)	1 / 2	2 / 3	1 / 2	2 / 3	
Implement Pump / Flow ¹	11.9 gpm (45 L)	12.6 gpm (47.7 L)	11.9 gpm (45 L)	12.6 gpm (47.7 L)	12.5 gpm (47.5 L)
3-point Hitch Category and Draft Sensing Type	1/2, Mechanical Draft Control (MDC) top link sensing				
Lower Link End / Stabilizer Type	Flex ends / Telescopic stabilizers	Fixed ends (flex ends optional) / Telescopic stabilizers	Flex ends / Telescopic stabilizers	Fixed ends (flex ends optional) / Telescopic stabilizers	Flex ends / Telescopic stabilizers
Lift Capacity @ 24 in. Behind Pin (Standard / Optional)	2,701 lb. (1 225 kg) / N/A	4,299 lb. (1 950 kg) / 4,740 lb. (2 150 kg)	2,701 lb. (1 225 kg) / N/A	4,299 lb. (1 950 kg) / 4,740 lb. (2 150 kg)	3,664 lb. (1 662 kg) / N/A
CAPACITIES					
Fuel Tank (Cab / Non-Cab)	Not offered / 17.2 gal (65 L)	21.7 gal (82 L) / Not offered	Not offered / 17.2 gal (65 L)	21.7 gal (82 L) / Not offered	23.8 gal (90 L) / Not offered
Diesel Exhaust Fluid Tank	No DEF required				
DIMENSIONS & WEIGHTS					
Wheelbase (2WD/MFD)	96.5 in. (2 450 mm) / 97.6 in. (2 478 mm)	81.2 in. (2 063 mm) / 81.8 in. (2 078 mm)	96.5 in. (2 450 mm) / 97.6 in. (2 478 mm)	81.2 in. (2 063 mm) / 81.8 in. (2 078 mm)	N/A / 84 in. (2 132 mm)
Overall Length (2WD/MFD)	129.5 in. (3 290 mm) / 134.0 in. (3 404 mm)	151.8 in. (3 856 mm)	129.5 in. (3 290 mm) / 134.0 in. (3 404 mm)	151.8 in. (3 856 mm)	
Minimum Height (ROPS Folded)	75.9 in. (1 930 mm)	Not offered	77 in. (1 957 mm)	Not offered	
Overall Height MFD (Top of Cab)	Not offered	100 in. (2 545 mm)	Not offered	100 in. (2 545 mm)	98 in. (2 495 mm)
Weight w/o Ballast (Cab/Non-Cab 2WD)	Not offered / 4,442 lb. (2 015 kg)	6,173 lb. (2 800 kg) / Not offered	Not offered / 4,442 lb. (2 015 kg)	6,173 lb. (2 800 kg) / Not offered	Not offered
Weight w/o Ballast (Cab/Non-Cab MFD)	Not offered / 5,060 lb. (2 295 kg)	6,834 lb. (3 100 kg) / Not offered	Not offered / 5,060 lb. (2 295 kg)	6,834 lb. (3 100 kg) / Not offered	6,239 lb. (2 830 kg) / Not offered

¹ At rated engine RPM

MODEL	FARMALL 70A	FARMALL 75A	FARMALL 75C
<i>SERIES CLASSIFICATION</i>	<i>STANDARD</i>		<i>DELUXE</i>
Operator Station	Non-cab	Cab/Non-cab	Cab/Non-cab
Traction	2WD/MFD	2WD/MFD	2WD ² /MFD
ENGINE			
Type	3-cylinder, Tier 4 B/Final, FPT turbocharged & aftercooled		4-cylinder, Tier 4 B/Final, FPT turbocharged
Displacement	2.2 L	2.9 L	3.4 L
Engine HP ¹	70	74	74
PTO HP ¹	61	60	64
Rated Engine RPM	2,600	2,300	
TRANSMISSION / PTO			
Standard	8×8 Mechanical shuttle (dry clutch)		12×12 Power shuttle (wet clutch)
Optional	N/A	12×12 Power shuttle (wet clutch) or 12×12 with creeper	8×8 Power shuttle (wet clutch) 12×12 Power shuttle (wet clutch) with creeper
Differential Lock	Mechanical		
MFD Engagement	Mechanical	Electrohydraulic	Electrohydraulic
PTO Speed (Standard / Optional)	540 / 540E	540 / 540/540E	540 / 540/540E
AXLES			
Front	2WD or MFD with limited slip		HD 2WD or MFD with limited slip
Rear	Flange		
HYDRAULICS / HITCH			
Type	Open center		
Rear Remotes (Standard / Optional)	1 / 2	2 / 3	2 / 3
Implement Pump / Flow ¹	11.9 gpm (45 L)	12.6 gpm (47.7 L)	12.5 gpm (47.5 L)
3-point Hitch Category and Draft Sensing Type	1/2, Mechanical Draft Control (MDC) top link sensing		
Lower Link End / Stabilizer Type	Flex ends / Telescopic stabilizers	Fixed ends (flex ends optional) / Telescopic stabilizers	Flex ends / Telescopic stabilizers
Standard Lift Capacity @ 24 in. Behind Pin (Standard / Optional)	2,701 lb. (1 225 kg) / N/A	4,299 lb. (1 950 kg) / 4,740 lb. (2 150 kg)	3,664 lb. (1 662 kg), / N/A
CAPACITIES			
Fuel Tank (Cab / Non-Cab)	Not offered / 17.2 gal (65 L)	21.7 gal (82 L)	23.8 gal (90 L)
Diesel Exhaust Fluid Tank	No DEF required		
DIMENSIONS & WEIGHTS			
Wheelbase (2WD/MFD)	96.5 in. (2 450 mm) / 97.6 in. (2 478 mm)	81.2 in. (2 063 mm) / 81.8 in. (2 078 mm)	86 in. (2 180 mm) / 84 in. (2 132 mm)
Overall Length (2WD/MFD)	129.5 in. (3 290 mm) / 134.0 in. (3 404 mm)	151.8 in. (3 856 mm)	153 in. (3 884 mm) / 151 in. (3 838 mm)
Minimum Height (ROPS Folded)	77 in. (1 957 mm)	67.7 in. (1 720 mm)	77.6 in. (1 972 mm)
Overall Height MFD (Top of Cab)	Not offered	100 in. (2 545 mm)	98 in. (2 495 mm)
Weight w/o Ballast (Cab/Non-Cab 2WD)	Not offered / 4,442 lb. (2 015 kg)	6,173 lb. (2 800 kg) / 5,622 lb. (2 550 kg)	5,622 lb. (2 550 kg) / 5,027 lb. (2 280 kg)
Weight w/o Ballast (Cab/Non-Cab MFD)	Not offered / 5,060 lb. (2 295 kg)	6,834 lb. (3 100 kg) / 6,283 lb. (2 850 kg)	6,239 lb. (2 830 kg) / 5,512 lb. (2 500 kg)

¹ At rated engine RPM ² 2WD not available on Hi-Lo models

MODEL	FARMALL 90C	FARMALL 95A	FARMALL 100C	FARMALL 105A	FARMALL 110C
SERIES CLASSIFICATION	DELUXE	STANDARD	DELUXE	STANDARD	DELUXE
Operator Station	Cab/Non-cab				
Traction	2WD ² / MFD	2WD / MFD	2WD ² / MFD	2WD / MFD	2WD ² / MFD
ENGINE					
Type	4-cylinder, Tier 4 B/Final, FPT turbocharged & aftercooled. Tier 4 B/Final - Stage V with 24×24 Hi-Lo transmission.				
Displacement	3.4 L (3.6 L with 24×24 Hi-Lo transmission)	3.4 L	3.4 L (3.6 L with 24×24 Hi-Lo transmission)	3.4 L	3.4 L (3.6 L with 24×24 Hi-Lo transmission)
Engine HP ¹	86	97	99	112	107
PTO HP ¹	73	78	85	92	93
Rated Engine RPM	2,300				
TRANSMISSION / PTO					
Standard	12×12 Power shuttle (wet clutch)	12×12 Power shuttle (wet clutch), creeper ready (20×20)	12×12 Power shuttle (wet clutch)	12×12 Power shuttle (wet clutch), creeper ready (20×20)	12×12 Power shuttle (wet clutch)
Optional	12×12 Power shuttle (wet clutch) w/ creeper, 24×24 Hi-Lo (wet clutch) w/ electrohydraulic shuttle	12×12 Mechanical shuttle (dry clutch), creeper ready (20×20)	12×12 Power shuttle (wet clutch) w/ creeper, 24×24 Hi-Lo (wet clutch) w/ electrohydraulic shuttle	12×12 Mechanical shuttle (dry clutch), creeper ready (20×20)	12×12 Power shuttle (wet clutch) w/ creeper, 24×24 Hi-Lo (wet clutch) w/ electrohydraulic shuttle
Differential Lock	12×12: Mechanical; Hi-Lo: Electrohydraulic	Mechanical	12×12: Mechanical; Hi-Lo: Electrohydraulic	Mechanical	12×12: Mechanical; Hi-Lo: Electrohydraulic
MFD Engagement	Electrohydraulic				
PTO Speed (Standard / Optional)	12×12: 540 / 540/1,000; Hi-Lo: 540/1,000	540 / 540/540E / 540/1,000	12×12: 540 / 540/1,000; Hi-Lo: 540/1,000	540 / 540/540E / 540/1,000	12×12: 540 / 540/1,000; Hi-Lo: 540/1,000
AXLES					
Front	12×12: HD 2WD or MFD or HD MFD with limited slip Hi-Lo: HD MFD with limited slip	2WD or MFD with limited slip	12×12: HD 2WD or MFD or HD MFD with limited slip Hi-Lo: HD MFD with limited slip	2WD or MFD with limited slip	12×12: HD 2WD or MFD or HD MFD with limited slip Hi-Lo: HD MFD with limited slip
Rear	Flange				
HYDRAULICS / HITCH					
Type	Open center				
Rear Remotes (Standard / Optional)	2 / 3				
Implement Pump / Flow ²	16.9 gpm (64 L)				
3-point Hitch Category and Draft Sensing Type	2, 12×12 MDC top link sensing Hi-Lo Cab EDC lower link Hi-Lo Non-cab MDC top link	1/2, Mechanical Draft Control (MDC) top link	2, 12×12 MDC top link sensing Hi-Lo Cab EDC lower link Hi-Lo Non-cab MDC top link	1/2, Mechanical Draft Control (MDC) top link	2, 12×12 MDC top link sensing Hi-Lo Cab EDC lower link Hi-Lo Non-cab MDC top link
Lower Link End / Stabilizer Type	Flex ends / Telescopic stabilizers				
Standard Lift Capacity @ 24 in. Behind Pin (Standard / Optional)	4,339 lb. (1,968 kg) / 5,620 lb. (2,549 kg)	3,200 lb. (1,451 kg) / 7,716 lb. (3,500 kg)	4,339 lb. (1,968 kg) / 5,620 lb. (2,549 kg)	3,200 lb. (1,451 kg) / 7,716 lb. (3,500 kg)	4,339 lb. (1,968 kg) / 5,620 lb. (2,549 kg)
CAPACITIES					
Fuel Tank (Cab / Non-Cab)	42.3 gal (160 L)	29 gal. (110 L) / 23 gal. (90 L)	42.3 gal (160 L)	29 gal. (110 L) / 23 gal. (90 L)	42.3 gal (160 L)
Diesel Exhaust Fluid Tank	2.5 gal (9.6 L)	2.9 gal. (11 L)	2.5 gal (9.6 L)	2.9 gal. (11 L)	2.5 gal (9.6 L)
DIMENSIONS & WEIGHTS					
Wheelbase (2WD / MFD)	92 in. (2,343 mm) / 90 in. (2,285 mm)	91 in. (2,310 mm) / 89 in. (2,260 mm)	92 in. (2,343 mm) / 90 in. (2,285 mm)	91 in. (2,310 mm) / 89 in. (2,260 mm)	92 in. (2,343 mm) / 90 in. (2,285 mm)
Overall Length (2WD / MFD)	163 in. (4,144 mm) / 161 in. (4,086 mm)	161.6 in. (4,105 mm)	163 in. (4,144 mm) / 161 in. (4,086 mm)	161.6 in. (4,105 mm)	163 in. (4,144 mm) / 161 in. (4,086 mm)
Minimum Height (ROPS Folded)	82.9 in. (2,106 mm) ³	72.8 in. (1,849 mm) ⁴	82.9 in. (2,106 mm) ³	72.8 in. (1,849 mm) ⁴	82.9 in. (2,106 mm) ³
Overall Height MFD (Top of Cab)	102.2 in. (2,595 mm) ³	106 in. (2,690 mm) ⁴	102.2 in. (2,595 mm) ³	106 in. (2,690 mm) ⁴	102.2 in. (2,595 mm) ³
Weight w/o Ballast (Cab/Non-Cab 2WD)	7,253 lb. (3,290 kg) / 6,768 lb. (3,070 kg)	8,173 lb. (3,715 kg) / 7,304 lb. (3,320 kg)	7,253 lb. (3,290 kg) / 6,768 lb. (3,070 kg)	8,173 lb. (3,715 kg) / 7,304 lb. (3,320 kg)	7,253 lb. (3,290 kg) / 6,768 lb. (3,070 kg)
Weight w/o Ballast (Cab/Non-Cab MFD)	8,157 lb. (3,700 kg) / 7,672 lb. (3,480 kg)	8,492 lb. (3,860 kg) / 7,689 lb. (3,495 kg)	8,157 lb. (3,700 kg) / 7,672 lb. (3,480 kg)	8,492 lb. (3,860 kg) / 7,689 lb. (3,495 kg)	8,157 lb. (3,700 kg) / 7,672 lb. (3,480 kg)

MODEL	FARMALL 110U	FARMALL 115A	FARMALL 120C	FARMALL 120U
SERIES CLASSIFICATION	PREMIUM	STANDARD	DELUXE	PREMIUM
Operator Station	Cab	Cab/Non-cab	Cab/Non-cab	Cab
Traction	MFD	2WD/MFD	2WD ² /MFD	MFD
ENGINE				
Type	4-cylinder, Tier 4 B/Final, FPT turbocharged & aftercooled			
Displacement	3.4 L		3.4 L (3.6 L with 24×24 Hi-Lo transmission)	3.4 L
Engine HP ¹	107	120	117	117
PTO HP ¹	93	100	100	100
Rated Engine RPM	2,300			
TRANSMISSION / PTO				
Standard	ActiveDrive 4 16×16 Semi-power shift	12×12 Power shuttle (wet clutch), creeper ready (20×20)	12×12 Power shuttle (wet clutch)	ActiveDrive 4 16×16 Semi-power shift
Optional	ActiveDrive 4 16×16 Semi-power shift w/ creeper	12×12 Mechanical shuttle (dry clutch), creeper ready (20×20)	12×12 Power shuttle (wet clutch) w/ creeper, 24×24 Hi-Lo (wet clutch) w/ electrohydraulic shuttle	ActiveDrive 4 16×16 Semi-power shift w/ creeper
Differential Lock	Electrohydraulic	Mechanical	12×12: Mechanical; Hi-Lo: Electrohydraulic	Electrohydraulic
MFD Engagement	Electrohydraulic			
PTO Speed (Standard / Optional)	540/1,000 / 540/540E/1,000	540 / 540/540E / 540/1,000	12×12: 540/540E / 540/1,000 Hi-Lo: 540/540E or 540/1,000	540/1,000 / 540/540E/1,000
AXLES				
Front	Standard MFD front axle/ Suspended MFD front axle	2WD or MFD with limited slip	12×12: HD 2WD or HD MFD with limited slip; Hi-Lo: HD MFD with limited slip	Standard MFD front axle/ Suspended MFD front axle
Rear	Flange			
HYDRAULICS / HITCH				
Type	Open center system, closed center load sensing (CCLS) remotes	Open center		Open center system, closed center load sensing (CCLS) remotes
Rear Remotes (Standard / Optional)	2 mechanical with configurable detents / 3 mechanical, 2 with configurable detents	2 / 3		2 mechanical with configurable detents / 3 mechanical, 2 with configurable detents
Implement Pump / Flow ¹	21.1 gpm (80 L)	16.9 gpm (64 L)		21.1 gpm (80 L)
3-point Hitch Category and Draft Sensing Type	2, Mechanical Draft Control (MDC) top link	1/2, Mechanical Draft Control (MDC) top link	2, 12×12 MDC top link sensing Hi-Lo Cab EDC lower link Hi-Lo Non-cab MDC top link	2, Mechanical Draft Control (MDC) top link
Lower Link End / Stabilizer Type	Flex ends / Telescopic stabilizers			
Standard Lift Capacity @ 24 in. Behind Pin (Standard / Optional)	8,809 lb. (3,996 kg) / N/A	3,200 lb. (1,451 kg) / 7,716 lb. (3,500 kg)	4,339 lb. (1,968 kg) / 5,620 lb. (2,549 kg)	8,809 lb. (3,996 kg) / N/A
CAPACITIES				
Fuel Tank (Cab / Non-Cab)	43.6 gal. (165 L)	29 gal. (110 L) / 23 gal. (90 L)	42.3 gal. (160 L)	43.6 gal. (165 L)
Diesel Exhaust Fluid Tank	3.2 gal. (12 L)	2.9 gal. (11 L)	2.5 gal. (9.6 L)	3.2 gal. (12 L)
DIMENSIONS & WEIGHTS				
Wheelbase (2WD / MFD)	Not offered / 93.7 in. (2,380 mm)	91 in. (2,310 mm) / 89 in. (2,260 mm)	92 in. (2,343 mm) / 90 in. (2,285 mm)	Not offered / 93.7 in. (2,380 mm)
Overall Length (2WD / MFD)	165 in. (4,191 mm)	161.6 in. (4,105 mm)	163 in. (4,144 mm) / 161 in. (4,086 mm)	165 in. (4,191 mm)
Minimum Height (ROPS Folded)	Not offered	72.8 in. (1,849 mm) ⁴	82.9 in. (2,106 mm) ⁴	Not offered
Overall Height MFD (Top of Cab)	107 in. (2,720 mm)	106 in. (2,690 mm) ⁴	102.2 in. (2,595 mm) ⁴	107 in. (2,720 mm)
Weight w/o Ballast (Cab/Non-Cab 2WD)	Not offered	8,173 lb. (3,715 kg) / 7,304 lb. (3,320 kg)	7,253 lb. (3,290 kg) / 6,768 lb. (3,070 kg)	Not offered
Weight w/o Ballast (Cab/Non-Cab MFD)	10,031 lb. (4,550 kg) / Not offered	8,492 lb. (3,860 kg) / 7,689 lb. (3,495 kg)	8,157 lb. (3,700 kg) / 7,672 lb. (3,480 kg)	10,031 lb. (4,550 kg) / Not offered

¹ At rated engine RPM ² 2WD not available on Hi-Lo models ³ At 1,535 engine rpm ⁴ With 18.4R34 rear tires



MODEL	FARMALL 110A PRO	FARMALL 120A PRO	FARMALL 130A PRO	FARMALL 140A PRO
<i>SERIES CLASSIFICATION</i>	STANDARD			
Operator Station	Cab	Cab/Non-cab	Cab	Cab/Non-cab
Traction	MFD		2WD/MFD	2WD (cab only)/MFD
ENGINE				
Type	4-cylinder, Tier 4 B/Final, FPT turbocharged & aftercooled			
Displacement	4.5 L			
Engine HP ¹	110	120	130	140
PTO HP ¹	92	102	112	118
Rated Engine RPM	2,200			
TRANSMISSION / PTO				
Standard	8 × 8 Power shuttle (wet clutch)			
Optional	16 × 8 Power shuttle (wet clutch)			
Differential Lock	Electrohydraulic			
MFD Engagement	Electrohydraulic			
PTO Speed (Standard / Optional)	540/1,000			
AXLES				
Front	HD MFD with limited slip		HD 2WD or HD MFD with limited slip	
Rear	Flange/bar			
HYDRAULICS / HITCH				
Type	Open center system, closed center load sensing (CCLS) remotes		Open center system, closed center load sensing (CCLS) remotes	
Rear Remotes (Standard / Optional)	2 / 3 or 4			
Implement Pump / Flow ¹	22 gpm (83 L)			
3-point Hitch Category and Draft Sensing Type	2, Mechanical Draft Control (MDC) Top link sensing			
Lower Link End / Stabilizer Type	Flex ends / Telescopic stabilizers			
Standard Lift Capacity @ 24 in. Behind Pin (Standard / Optional)	7,200 lb. (3,266 kg) / 5,400 lb. (2,449 kg)			
CAPACITIES				
Fuel Tank (Cab / Non-Cab)	56.8 gal. (215 L)			
Diesel Exhaust Fluid Tank	7.9 gal. (30 L)			
DIMENSIONS & WEIGHTS				
Wheelbase (2WD / MFD)	Not offered / 103.9 in (2640 mm)		95.7 in (2432 mm) / 103.9 in (2640 mm)	
Overall Length (2WD / MFD)	184.7 in. (4690 mm)			
Minimum Height (ROPS Folded)	Not offered	90.6 in. (2300 mm)	Not offered	90.6 in. (2300 mm)
Overall Height MFD (Top of Cab)	110.2 in. (2800 mm) ²			
Weight w/o Ballast (Cab/Non-Cab 2WD)	Not offered	Not offered	9,414 lb. (4,270 kg) / Not offered	
Weight w/o Ballast (Cab/Non-Cab MFD)	10,538 lb. (4,780 kg) / Not offered		10,648 lb. (4,830 kg) / Not offered	10,648 lb. (4,830 kg) / 9,965 lb. (4,520 kg)

¹At rated engine RPM ²With 18.4R38 rear tires

TIRE SELECTIONS AVAILABLE FROM THE FACTORY

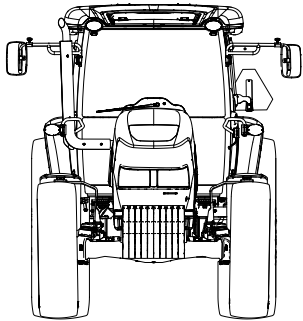

SMALL UTILITY



FARMALL UTILITY MODEL	50A	55A	60A	65A	65C	70A	75A	75C
 Agricultural tread (R-1)	✓	✓	✓	✓	✓	✓	✓	✓
 Turf tread (R-3)	✓		✓		✓	✓		✓
 Industrial tread (R-4)	✓	✓	✓	✓	✓	✓	✓	✓

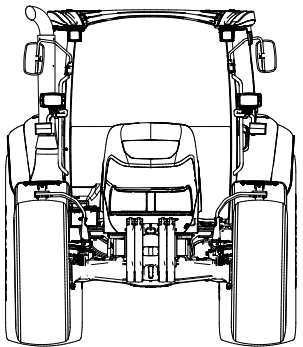

MEDIUM UTILITY

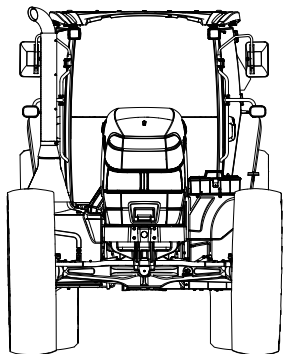

FARMALL UTILITY MODEL	90C	95A	100C	105A	110C	110U	115A	120C	120U
 Agricultural tread (R-1)	✓	✓	✓	✓	✓	✓	✓	✓	✓
 Turf tread (R-3)									
 Industrial tread (R-4)	✓	✓	✓	✓	✓		✓	✓	

LARGE UTILITY



FARMALL UTILITY MODEL	110A PRO	120A PRO	130A PRO	140A PRO
 Agricultural tread (R-1)	✓	✓	✓	✓
 Turf tread (R-3)				
 Industrial tread (R-4)				



A FULL LINE OF ATTACHMENTS, IMPLEMENTS AND LOADERS

QUICK AND EASY ATTACHMENTS AND IMPLEMENTS.

• With a heavy-duty 3-point hitch, high-capacity responsive hydraulics and independent PTO, your Farmall utility series tractor is ready for action with any of the following Case IH attachments or implements:

- Rear-mount finishing mowers
- Rotary tillers
- Rotary cutters
- Box blades
- Landscape rakes
- Disk harrows
- Backhoes
- Rear blades
- Bale handling
- Buckets
- Grapple buckets
- Pallet handling
- Silage handling



	REAR MOUNT FINISH MOWERS						BACKHOES		TILLERS		ROTARY CUTTERS									
	RR60	RR72	RR90	RR144	RR180	RR204	BHA90	BHA102	TL160	TL172H	RC480	RC600	RC605	RC720	RC725	RC727	RC840	RC845	RC1440	RC1800
SMALL UTILITY TRACTORS																				
Farmall utility 50A		✓	✓	✓				✓		✓				✓	✓	✓	✓	✓		
Farmall utility 55A			✓	✓	✓					✓				✓	✓	✓	✓	✓		
Farmall utility 60A		✓	✓	✓	✓			✓		✓				✓	✓	✓	✓	✓		
Farmall utility 65A			✓	✓	✓	✓				✓				✓	✓	✓	✓	✓		
Farmall utility 65C			✓	✓	✓	✓				✓				✓	✓	✓	✓	✓		
Farmall utility 70A		✓	✓	✓	✓	✓		✓		✓				✓	✓	✓	✓	✓	✓	
Farmall utility 75A			✓	✓	✓	✓				✓				✓	✓	✓	✓	✓	✓	
Farmall utility 75C			✓	✓	✓	✓				✓				✓	✓	✓	✓	✓	✓	
MEDIUM UTILITY TRACTORS																				
Farmall utility 90C			✓	✓	✓	✓				✓							✓	✓	✓	✓
Farmall utility 95A			✓	✓	✓	✓				✓				✓	✓	✓	✓	✓	✓	✓
Farmall utility 100C			✓	✓	✓	✓				✓							✓	✓	✓	✓
Farmall utility 105A			✓	✓	✓	✓				✓				✓	✓	✓	✓	✓	✓	✓
Farmall utility 110C			✓	✓	✓	✓				✓							✓	✓	✓	✓
Farmall utility 110U			✓	✓	✓	✓											✓	✓	✓	✓
Farmall utility 115A			✓	✓	✓	✓				✓				✓	✓	✓	✓	✓	✓	✓
Farmall utility 120C			✓	✓	✓	✓				✓							✓	✓	✓	✓
Farmall utility 120U			✓	✓	✓	✓											✓	✓	✓	✓
LARGE UTILITY TRACTORS																				
Farmall utility 110A				✓	✓	✓											✓	✓	✓	✓
Farmall utility 120A				✓	✓	✓											✓	✓	✓	✓
Farmall utility 130A				✓	✓	✓											✓	✓	✓	✓
Farmall utility 140A				✓	✓	✓											✓	✓	✓	✓

	DISK HARROW	LANDSCAPE RAKES		BOX BLADES					REAR BLADES				
	EZ78DC	EZ72LR	EZ84LR	EZ48BL	EZ60BL	EZ60BM	EZ72BM	EZ84BM	EZ60SM	EZ72SM	EZ84SM	EZ84SH	EZ96SH
SMALL UTILITY TRACTORS													
Farmall Utility 50A	✓	✓	✓				✓	✓		✓	✓	✓	
Farmall Utility 55A	✓	✓	✓				✓	✓		✓	✓	✓	
Farmall Utility 60A	✓	✓	✓				✓	✓		✓	✓	✓	
Farmall Utility 65A	✓	✓	✓				✓	✓		✓	✓	✓	
Farmall Utility 65C	✓	✓	✓				✓	✓		✓	✓	✓	
Farmall Utility 70A	✓	✓	✓				✓	✓		✓	✓	✓	✓
Farmall Utility 75A	✓	✓	✓				✓	✓		✓	✓	✓	✓
Farmall Utility 75C	✓	✓	✓				✓	✓		✓	✓	✓	✓
MEDIUM UTILITY TRACTORS													
Farmall Utility 90C	✓	✓	✓					✓		✓	✓	✓	✓
Farmall Utility 95A	✓	✓	✓					✓		✓	✓	✓	✓
Farmall Utility 100C	✓	✓	✓					✓		✓	✓	✓	✓
Farmall Utility 105A	✓	✓	✓					✓		✓	✓	✓	✓
Farmall Utility 110C	✓	✓	✓					✓		✓	✓	✓	✓
Farmall Utility 110U			✓					✓		✓	✓	✓	✓
Farmall Utility 115A	✓	✓	✓					✓		✓	✓	✓	✓
Farmall Utility 120C	✓	✓	✓					✓		✓	✓	✓	✓
Farmall Utility 120U			✓					✓		✓	✓	✓	✓
LARGE UTILITY TRACTORS													
Farmall Utility 110A			✓					✓			✓	✓	✓
Farmall Utility 120A			✓					✓			✓	✓	✓
Farmall Utility 130A			✓					✓			✓	✓	✓
Farmall Utility 140A			✓					✓			✓	✓	✓

CASE IH LOADERS ARE READY TO WORK FOR YOU.

- Case IH loaders are easy to install — just drive the tractor into the loader, put in the pins, attach the hydraulics and start working.
- Unobstructed forward sight lines let you easily see to the top of the bucket and around the front tires.
- Optional rear weights and ballast boxes are also available for more demanding loader work.



MODEL	LOADER	MAX. LIFT CAPACITY 31.5 in. (800 mm) Forward of Pivot Pin		MAX. HEIGHT Under Level Bucket	
		Non Self-leveling (NSL)	Mechanical Self-leveling (MSL)	Non Self-leveling (NSL)	Mechanical Self-leveling (MSL)
<i>SMALL UTILITY TRACTORS</i>					
50A, 60A, 70A	L545	1,742 lb. (790 kg)	2,205 lb. (1 000 kg)	102 in. (2 590 mm)	106 in. (2 680 mm)
	L555	1,940 lb. (880 kg)	2,734 lb. (1 240 kg)	105 in. (2 670 mm)	
55A, 65A, 75A	L610 ²	1,828 lb. (829 kg)	3,153 lb. (1 430 kg)	120 in. (3 040 mm)	
65C, 75C	L565	1,940 lb. (880 kg)	2,734 lb. (1 240 kg)	105 in. (2 670 mm)	
	L620	2,478 lb. (1 124 kg)	3,179 lb. (1 442 kg)	114 in. (2 910 mm)	
<i>MEDIUM UTILITY TRACTORS</i>					
95A, 105A, 115A	L575	2,028 lb. (920 kg)	3,174 lb. (1 440 kg)	134.5 in. (3 416 mm)	
90C, 100C, 110C, 120C	L575	2,028 lb. (920 kg)	3,175 lb. (1 440 kg)	125 in. (3 180 mm)	
	L103	2,205 lb. (1 000 kg)	3,241 lb. (1 470 kg)	129 in. (3 270 mm)	
	L620	2,478 lb. (1 124 kg)	3,179 lb. (1 442 kg)	114 in. (2 910 mm)	
	L630 ²	2,632 lb. (1 194 kg)	3,428 lb. (1 555 kg)	123 in. (3 131 mm)	124 in. (3 149 mm)
110U, 120U	L103	2,359 lb. (1 070 kg)	3,461 lb. (1 570 kg)	132 in. (3 350 mm)	
<i>LARGE UTILITY TRACTORS</i>					
110A, 120A, 130A, 140A	L103 ¹	2,094 lb. (950 kg)	N/A	133 in. (3 370 mm)	N/A
	L104 ²	2,557 lb. (1 160 kg)	3,814 lb. (1 730 kg)	139 in. (3 530 mm)	

¹Only compatible with 2WD. ²Only compatible with MFD.



OPTUM®

MODEL	270	300
PTO HP	240	267



PUMA® Long Wheel Base

MODEL	185	200	220	240
PTO HP	150	170	190	210



PUMA® Short Wheel Base

MODEL	150	165
PTO HP	125	140



MAXXUM® ActiveDrive 8 & CVXDrive™

MODEL	115	125	135	145	150
PTO HP	95	105	110	120	125



MAXXUM® ActiveDrive 4

MODEL	115	125	135	145	150
PTO HP	95	105	110	120	125



VESTRUM®

MODEL	100	130
PTO HP	76	102



FARMALL® 100A PRO

MODEL	110A	120A	130A	140A
PTO HP	92	102	112	118



FARMALL® UTILITY U

MODEL	110U	120U
PTO HP	93	100



FARMALL® UTILITY C

MODEL	65C	75C	90C	100C	110C	120C
PTO HP	50	64	73	85	93	100



FARMALL® UTILITY A

MODEL	50A	55A	60A	65A	70A	75A	95A	105A	115A
PTO HP	45	43	51	51	61	60	78	92	100



FARMALL® N & V

MODEL	80N	100N	110N	80V	110V
PTO HP	62	86	93	65	93



SELF-PROPELLED WINDROWERS

MODEL	WD1505	WD2105	WD2505
HP	150	210	250



LARGE SQUARE BALERS

MODEL	LB334XL	LB434XL	LB436 HD
BALE SIZE	32"×35"	47"×35"	47"×36"
MIN. PTO HP	109-136	130-160	250



SMALL SQUARE BALERS

MODEL	SB531	SB541	SB541C
BALE SIZE	14"×18"	14"×18"	14"×18"
MIN. PTO HP	62	75	75



ROUND BALERS

MODEL	RB455	RB465	RB565
BALE SIZE	36"-60"	36"-72"	36"-72"
MIN. PTO HP	60-100	70-105	85



UTILITY ROUND BALER

MODEL	RB455A
BALE SIZE	36"-60"
MIN. PTO HP	40



DISC MOWER CONDITIONERS

MODEL	SIDE-PULL		CENTER-PIVOT	
	DC93	DC103	DC133	DC163
CUT WIDTH	9' 2"	10' 4"	13'	16'
MIN. PTO HP	65	80	90	100



FORAGE EQUIPMENT

PULL-TYPE HARVESTER			SILAGE BLOWER		
MODEL	HDX300	HDX3R	HDX20P	600	
MIN. PTO HP	180	NO. OF ROWS	3	PICKUP WIDTH	8' 2 1/2"
				MIN. PTO HP	60



MOUNTED & TRAILED DISC MOWERS

MODEL	MOUNTED			TRAILED
	MD73	MD83	MD93	TD103
CUT WIDTH	6' 8"	7' 10"	9' 2"	10' 4"
MIN. PTO HP	45	55	60	60



WHEEL RAKES

MODEL	WR102	WR201	WR302
MAX. RAKING WIDTH	24' 6"	20' 4"	31'
NO. OF WHEELS	8, 10 or 12	8 or 10	12, 14 or 16

SAFETY NEVER HURTS!™ Always read the Operators Manual before operating any equipment. Inspect equipment before using it, and be sure it is operating properly. Follow the product safety signs, and use any safety features provided. CNH Industrial America LLC reserves the right to make improvements in design and changes in specifications at any time without notice and without incurring any obligation to install them on units previously sold. Specifications, descriptions and illustrative material herein are as accurate as known at time of publication, but are subject to change without notice. Availability of some models and equipment builds varies according to the country in which the equipment is used.

